

1245

1246

TEILELISTE

PARTS LIST

LISTE DE PIÈCES

零件表

Diese Teileliste hat für Maschinen ab nachfolgender Seriennummer Gültigkeit:

This parts list applies to machines from the following serial numbers onwards:

Cette liste de pièces est valable pour les machines au numéros de série à partir de:

本零件表对从下列系列号起的机器有效:

2 726 559 →

Alle Informationen und Abbildungen waren zum Zeitpunkt der Druckgebung auf dem neusten Stand.

Technische Änderungen vorbehalten!

Der Nachdruck, die Vervielfältigung sowie die Übersetzung - auch auszugsweise - aus PFAFF-Teilelisten ist nur mit unserer vorherigen Zustimmung und mit der Quellenangabe gestattet.

At the time of printing, all information and illustrations contained in this document were up to date.

Subject to alteration!

The reprinting, copying or translation of PFAFF Parts lists whether in whole or in part, is only permitted with our previous permission and with written reference to the source.

Todas las informaciones e ilustraciones de este manual estaban al día en el momento de entregarse para su impresión.

¡ Salvo modificaciones técnicas!

La reimpresión, reproducción y traducción - aunque sólo sea parcial - de las listas de piezas PFAFF sólo está permitida con nuestro permiso previo e indicando la fuente.

所有信息和图片在付印时都是最新的。

保留技术更改的权力！

全部或部分翻印、复制以及翻译PFAFF-零件表必须事先经由我们同意并且注明来源。

**PFAFF Industriesysteme
und Maschinen AG**

Hans-Geiger-Str. 12 - IG Nord

D-67661 Kaiserslautern

| | Seite Page Página 页 |
|--|-------------------------------------|
| 0 Wichtiger Hinweis | 5 |
| Important note | |
| Observación importante | |
| 重要提示 | |
| 1 Vorwort | 6 |
| Foreword | |
| Notas preliminares | |
| 前言 | |
| 2 Erläuterungen der Schlüsselzeichen | 7 |
| Explanation of key markings | |
| Explicaciones de los signos clave | |
| 标记说明 | |
| 3 Basismaschine | |
| Basic machine | |
| Máquina básicas | |
| 基础机器 | |
| 3.01 Gehäuseteile | 9 |
| Housing sections | |
| Piezas del cárter | |
| 机身零件 | |
| 3.02 Kopfteile | 10 |
| Needle head parts | |
| Piezas de la cabeza | |
| 机头零件 | |
| 3.03 Armteile | 14 |
| Arm parts | |
| Piezas del brazo | |
| 机臂零件 | |
| 3.04 Grundplattenteile | 20 |
| Bedplate parts | |
| Piezas del cárter | |
| 底板零件 | |
| 4 Abweichende Teile der PFAFF 1246 | 27 |
| Different parts for PFAFF 1246 | |
| Piezas de la PFAFF 1246 que son diferentes | |
| PFAFF 1246 中有差别的零件 | |
| 5 Nähfuß heben über Pedal (-910/01) | 32 |
| Raiser presser foot via the pedal (-910/01) | |
| Elevación del prensatelas mediante pedal (-910/01) | |
| 用踏板抬起压脚 (-910/01) | |
| 6 Garnrollenständer | 33 |
| Reel stands | |
| Portacarretes | |
| 线轴支架 | |

| | Seite Page Página 页 |
|--|------------------------------|
| 7 Einstellehren | 34 |
| Adjustment gauges | |
| Calibres de ajuste | |
| 设置量规 | |
| 8 Teile zur Tischplatte | 34 |
| Parts for table top | |
| Piezas para el tablero | |
| 用于台板的零件 | |
| 9 Keilriemen | 35 |
| V-belt | |
| Correa trapezoidal | |
| 三角皮带 | |
| 10 Knielüfterteile | 35 |
| Knee lifter parts | |
| Piezas del alzaprensatelas por rodillera | |
| 膝松线器零件 | |
| 11 Schmiermittel-Übersicht | 36 |
| Overview of lubricants | |
| Tabla de lubricantes | |
| 润滑剂一览 | |
| 12 Index (Teilenummern / Seitenzahlen) | 37 |
| Index (part numbers / page numbers) | |
| Index (números de pieza / números de página) | |
| 注脚(零件号/页号) | |
| 13 Unterklassen-Ausstattung | |
| Subclass parts | |
| Composición de las subclases | |
| 子机型-设备 | |
| 13.01 Nähwerkzeuge (PFAFF 1245) | 42 |
| Gauge parts (PFAFF 1245) | |
| Organos de costura (PFAFF 1245) | |
| 缝纫工具 (PFAFF 1245) | |
| 13.02 Nähwerkzeuge (PFAFF 1246) | 44 |
| Gauge parts (PFAFF 1246) | |
| Organos de costura (PFAFF 1246) | |
| 缝纫工具 (PFAFF 1246) | |

Achtung!



Wir machen ausdrücklich darauf aufmerksam, daß Ersatz- und Zubehörteile, die nicht von uns geliefert werden, auch nicht von uns geprüft und freigegeben sind. Der Einbau und / oder die Verwendung solcher Produkte kann daher u. Umständen konstruktiv vorgegebene Eigenschaften Ihrer Maschine negativ verändern. Für Schäden, die durch die Verwendung von Nicht-Originalteilen entstehen, übernehmen wir keine Haftung!

Caution!



We warn you expressively that spare parts and accessories that are not supplied by us are not tested and released by us. Fitting or using these products may therefore have negative influences on features that depend on the machine design. We are not liable for any damage caused by the use of non-Pfaff parts!

¡Atención!



Se hace observar que en el caso de piezas de recambio y accesorios que no hayan sido suministrados por nosotros, quiere decir que non han sido sometidas por nuestra parte a un control y que no se les ha dado el visto bueno. Por esta razón, el montaje y/o empleo de tales productos puede repercutir negativamente en las características previstas en su máquina. ¡Para los daños que eventualmente pudiesen presentarse al utilizar piezas no originales, no asumimos ninguna garantía!

注意!



我们必须明确指出，所有不是由我们供货的备件和附件都未经我们检查，也没有被我们批准使用。装入和/或使用这些产品可能在一定的情况下会对机器的设计特性造成负面改变。对由于使用非原装件所造成的损失，我们不负任何责任!

- Die Seriennummer der Maschine, für die diese Teileliste Gültigkeit hat, ist auf der Titelseite aufgeführt.
 - Alle Teile sind so abgebildet, wie sie in der Maschine funktionsmäßig zusammengehören.
 - Gestrichelt dargestellte Teile zeigen angrenzende Teile aus anderen Funktionsgruppen.
 - Im oberen Teil der Bildseiten befindet sich eine Gesamtansicht der Maschine .
 - Der Einbauort der dargestellten Teile wird durch eine gerasterte Fläche gekennzeichnet.
 - Einrahmungen auf den Bildseiten zeigen, aus welchen Einzelteilen sich die Gruppenteile zusammensetzen.
 - Die auf den Bildseiten verwendeten Schlüsselzeichen (; 2 ; 3 usw.) sind im Kapitel "Erläuterungen der Schlüsselzeichen" aufgelistet.
-
- The serial number of the machine to which this parts list applies is indicated on the cover page.
 - All parts are illustrated in function groups with the parts which they function together with in the machine.
 - Parts illustrated with broken lines are parts from other function groups which border on the illustrated function group.
 - The above section of the page of illustrations contains a total view of the machine. The place for the installation of the parts pictured here is marked by the grid.
 - The framed-in sections on the illustration pages show the individual parts comprising a group.
 - The key markings used on the illustrated pages (; 2 ; 3 etc.) are listed in the chapter "Explanation of key markings".
-
- El número de serie de la máquina para la cual tiene validez esta lista de piezas va indicado en la página de título.
 - Todas las piezas están ilustradas tal como aparecen en la máquina para su funcionamiento.
 - Las piezas representadas con rayitas muestran piezas colindantes de otros grupos de funciones.
 - En la parte superior de las páginas ilustradas se puede ver una vista en conjunto de la máquina.
 - El lugar de montaje de la pieza representada va caracterizada mediante una superficie reticulada.
 - Los recuadros en las páginas ilustradas indican las piezas individuales de que se componen los grupos.
 - Los signos clave (; 2 ; 3 etc.) empleados en las páginas con ilustraciones van listados en el capítulo "Explicaciones de los signos clave".
-
- 适用于本零件表的机器系列号列在首页上。
 - 所有的零件都按照其在机器中的功能情况合在一起表达。
 - 用虚线表示的零件为相邻功能组中的零件。
 - 图的上部为机器全景。
 - 所示零件的安装部位用影格面表示。
 - 页上的框表示这套组件都由哪些零件所组成。
 - 图页上所使用的标记（ ; 2 ; 3 等）列表在“标记说明”中。

- []** **Unterklassenabhängig, Teilenummer siehe Unterklassen-Ausstattung.**
Subclas-dependent, for part number see subclass parts listing.
Dependientes de la subclase, para el número de pieza véase "Dotación de subclases".
取决于子机型，零件号见子机型设备。
- C** **Maschinen-Ausstattung für mittelschwere Materialien.**
Model C for sewing medium-heavy materials.
Tipo C para materiales semipesados.
用于中偏厚料的机器设备。
- N** **Stichlänge 6,0 mm.**
Stitch lenght 6.0 mm.
Largo de puntada 6,0 mm
针距6.0 mm。
- N8** **Stichlänge 8,0 mm.**
Stitch lenght 8.0 mm.
Largo de puntada 8,0 mm
针距8.0 mm。
- P** **Teile zum Hüpftransport.**
Components of four-motion drop feed.
Piezas del transportador inferior a cuatro tiempos.
下送料装置中的零件
- 3** **Geklebt**
Part cemented
Pieza pegada
被粘住。
- 5** **Nähmuster bzw. Material einsenden.**
Submit sewing sample or material.
Envíense muestras de costura.
投寄缝纫样品及缝料。
- 6** **Nadeldicke und Spitzenform bei Bestellung angeben.**
Needle size and style of point to be stated on order.
Grosor de aguja y forma de la punta, indíquese en los pedidos.
在订货时给出针厚和针尖型式。
- 27/2** **Eingeklammerte Zahl = Dicke in mm.**
Number in brackets = thickness in mm.
Cifra entre paréntesis = espesor en mm.
括起的数字 = 厚度 (单位 mm)
- 27/5** **Eingeklammerte Zahl = Länge in mm.**
Number in brackets = length in mm.
Cifra entre paréntesis = largura en mm.
被括起的数字=长度，单位mm。
- 35/4** **Bei Montage bohren und verstiften.**
To be drilled and pinned after assembly.
Debera bacerse un taladro y colocarse un pasador antes del montaje.
在安装时钻孔和加定位销
- 40/1** **Füllen mit 28-011 201-44; Bestellnummer siehe Seite 36.**
Top up with 28-011 201-44; for part number see page 36.
Rellene con 28-011 201-44; para el número de pedido véase la página 36.
注油用 28-011 201-44; 订货号见 36页。

- 40/2** Tränken mit 28-011 201-44; Bestellnummer siehe Seite 36.
Grease with 28-011 201-44; for part number see page 36.
Engrase con grasa 28-011 201-44; para el número de pedido véase la página 36.
浸油用 28-011 201-44; 订货号见 36 页。
- 40/3** Fetten mit 28-011 202-47; Bestellnummer siehe Seite 36.
Grease with 28-011 202-47; for part number see page 36.
Engrase con grasa 28-011 202-47; para el número de pedido véase la página 36.
上脂用 28-011 202-47; 订货号见 36 页。
- 40/4** Fetten mit 28-011 202-43; Bestellnummer siehe Seite 36.
Grease with 28-011 202-43; for part number see page 36.
Engrase con grasa 28-011 202-43; para el número de pedido véase la página 36.
上脂用 28-011 202-43; 订货号见 36 页。
- 40/13** Fetten mit 28-011 202-05; Bestellnummer siehe Seite 36.
Grease with 28-011 202-05; for part number see page 36.
Engrase con grasa 28-011 202-05; para el número de pedido véase la página 36.
上脂用 28-011 202-05; 订货号见 36 页。
- 90/47** Nr. 91-141 572-12 mitbestellen.
Include No. 91-141 572-12 in your order.
Pidase juntamente el N° 91-141 572-12.
随同订购编号 91-141 572-12.

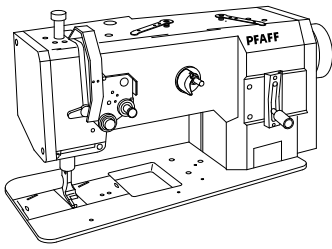

Gehäuseteile
Housing sections
Piezas del cárter
机身零件

PFAFF 1245

3.01

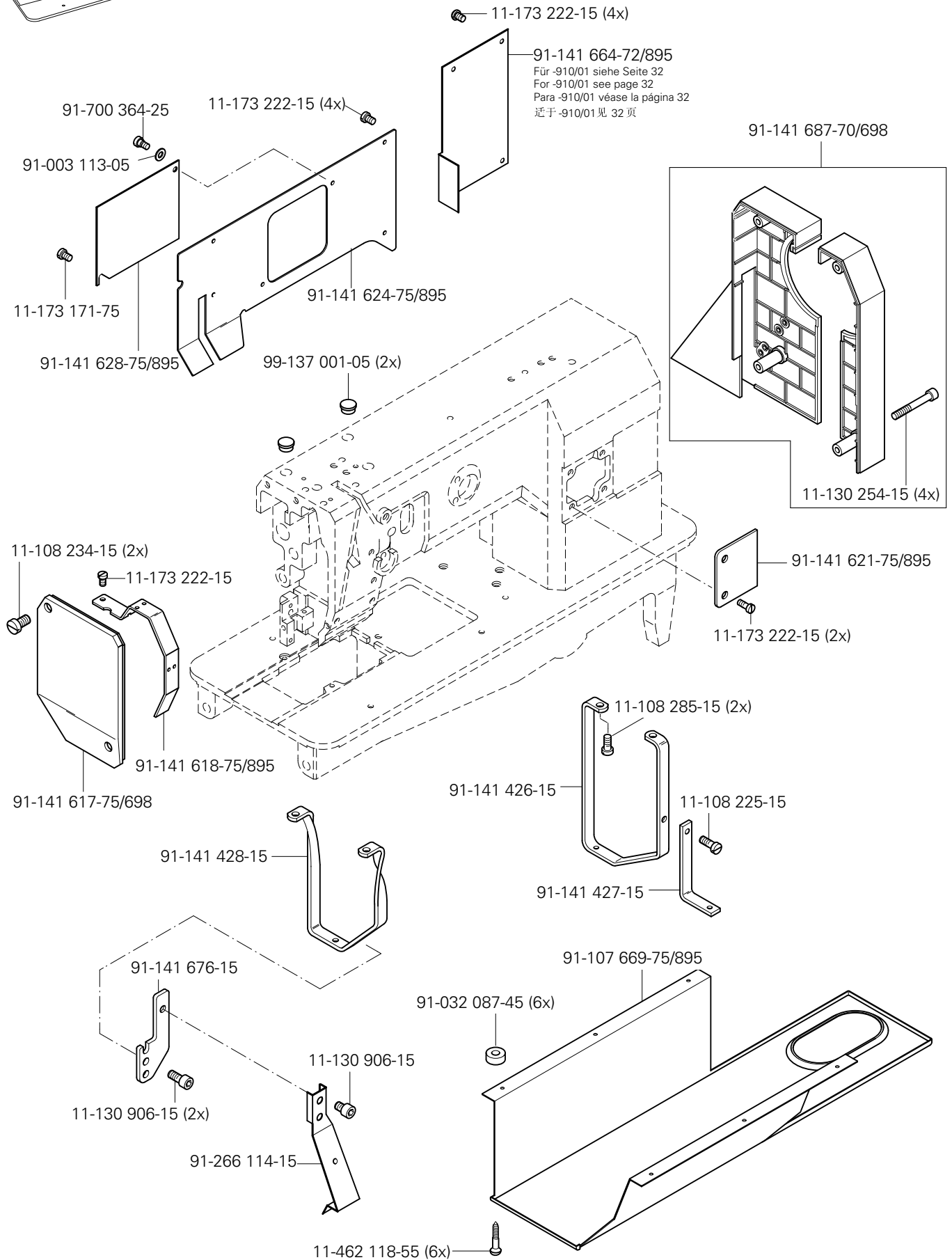

3.02

Kopfteile Needle head parts Piezas de la cabeza 机头零件

PFAFF 1245

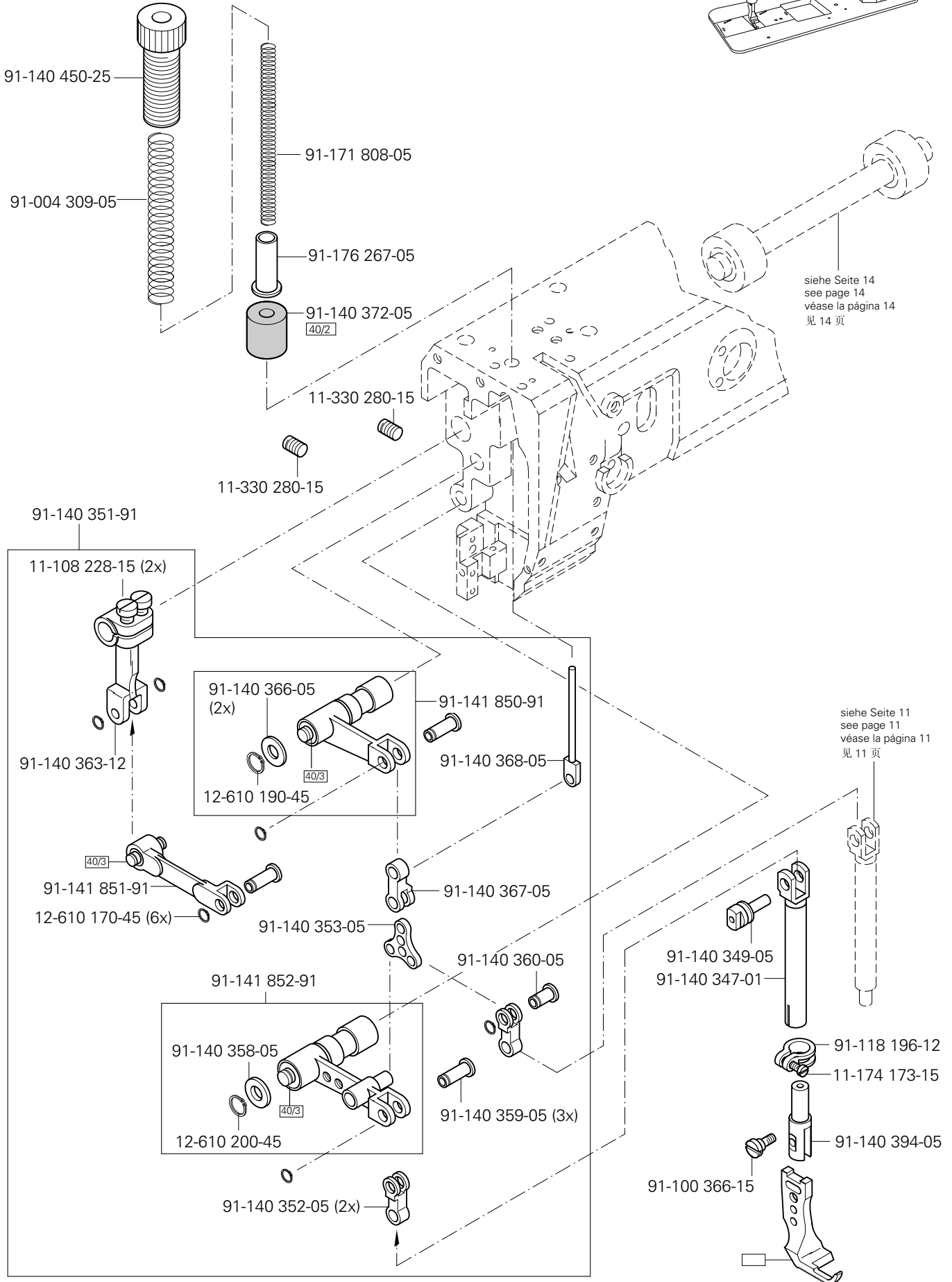
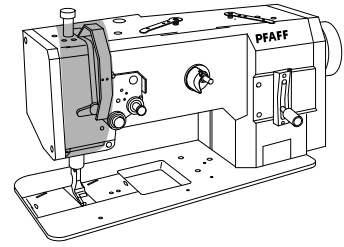

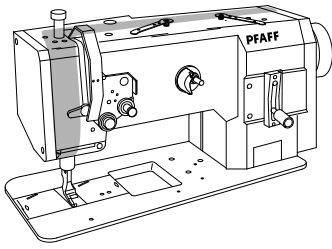

Kopfteile
Needle head parts
Piezas de la cabeza
机头零件

PFAFF 1245

3.02

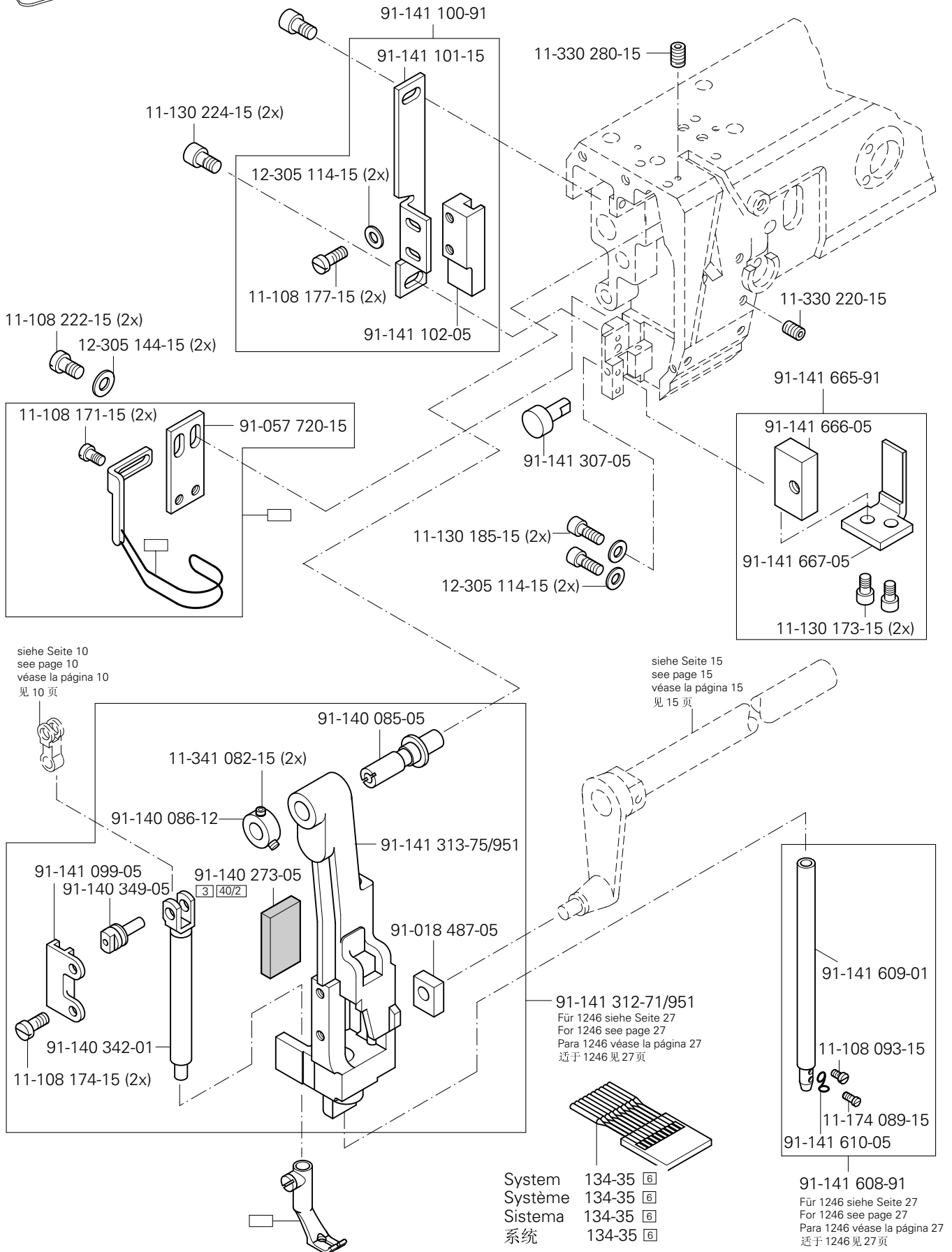

☐ siehe Kapitel 2 Erläuterung der Schlüsselzeichen
see chapter 2 Explanation of key markings
véase el Cap. 2 Explicaciones de los signos clave
见第2章标记说明

3.02

Kopfteile
Needle head parts
Piezas de la cabeza
机头零件

PFAFF 1245

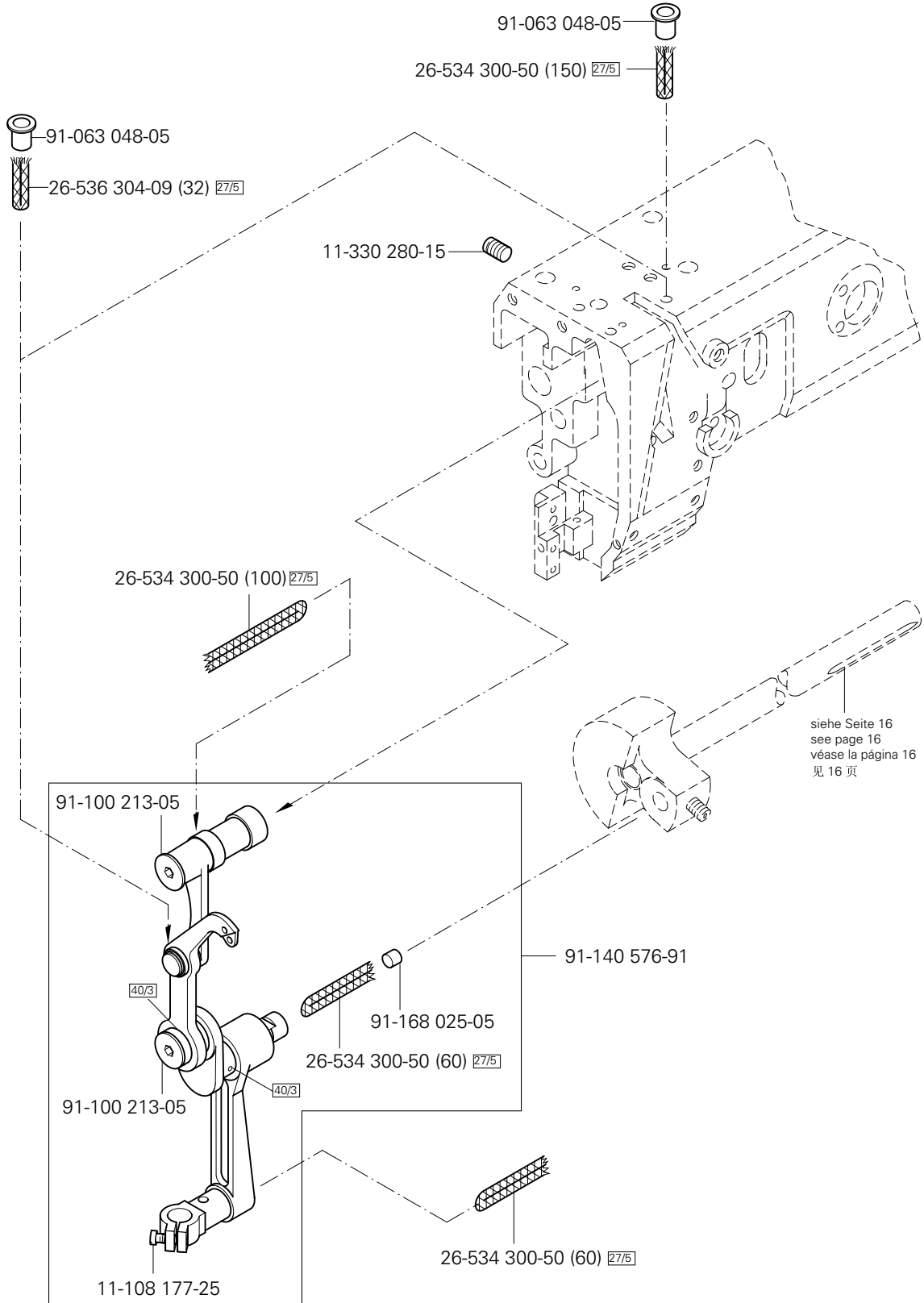
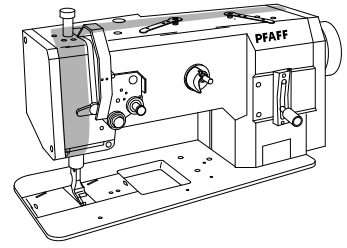

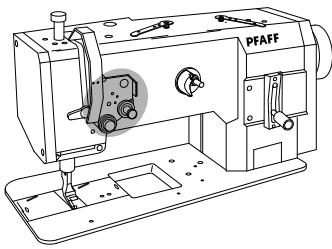

Kopfteile
Needle head parts
Piezas de la cabeza
机头零件

PFAFF 1245

3.02

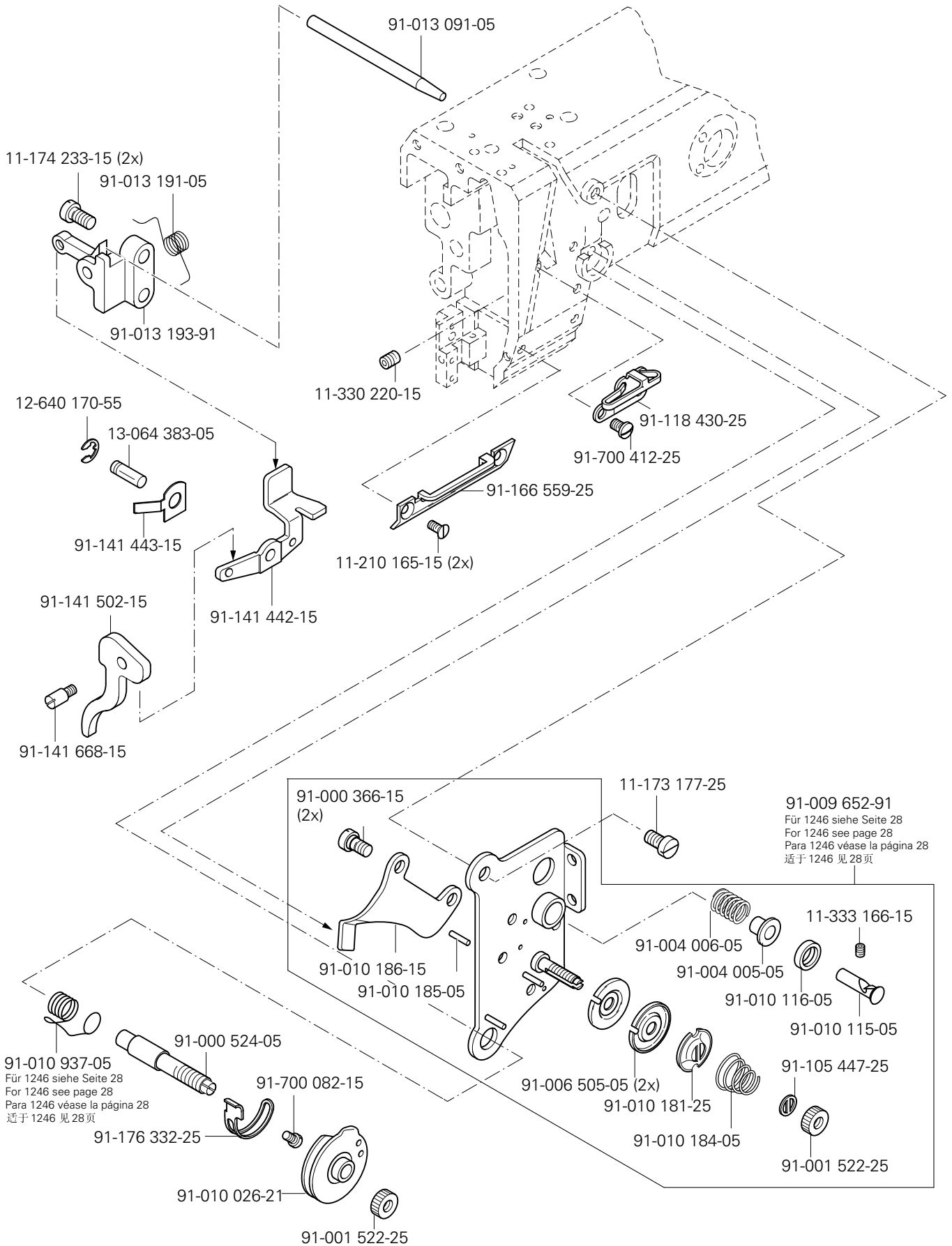

☐ siehe Kapitel 2 Erläuterung der Schlüsselzeichen
see chapter 2 Explanation of key markings
véase el Cap. 2 Explicaciones de los signos clave
见第2章标记说明

3.03

Armteile
 Arm parts
 Piezas del brazo
 机臂零件

PFAFF 1245

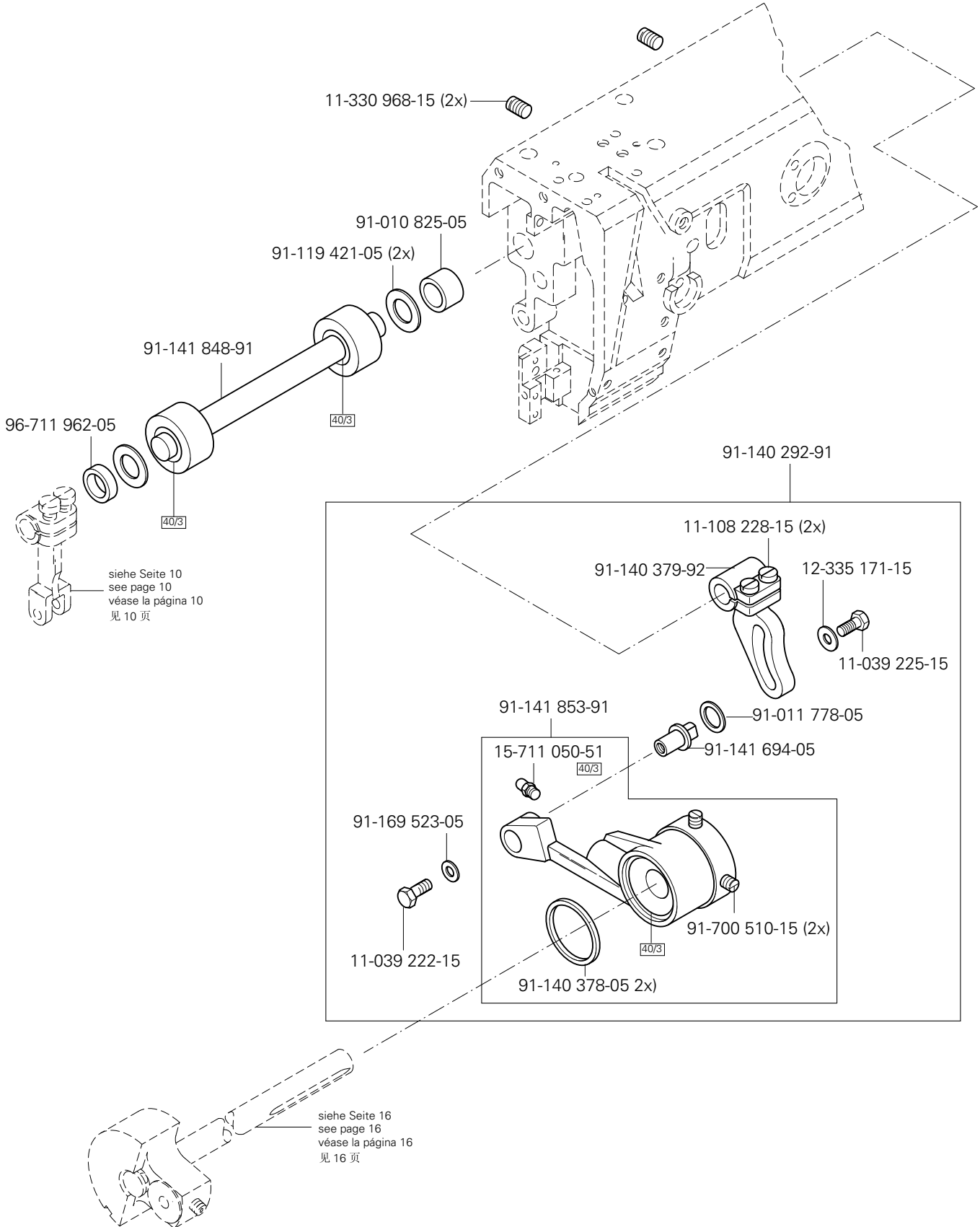
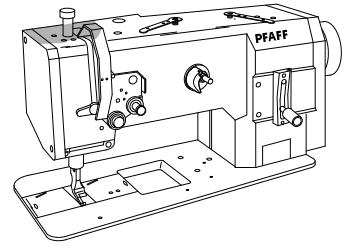

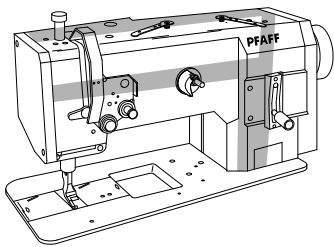

Armteile
 Arm parts
 Piezas del brazo
 机臂零件

PFAFF 1245

3.03

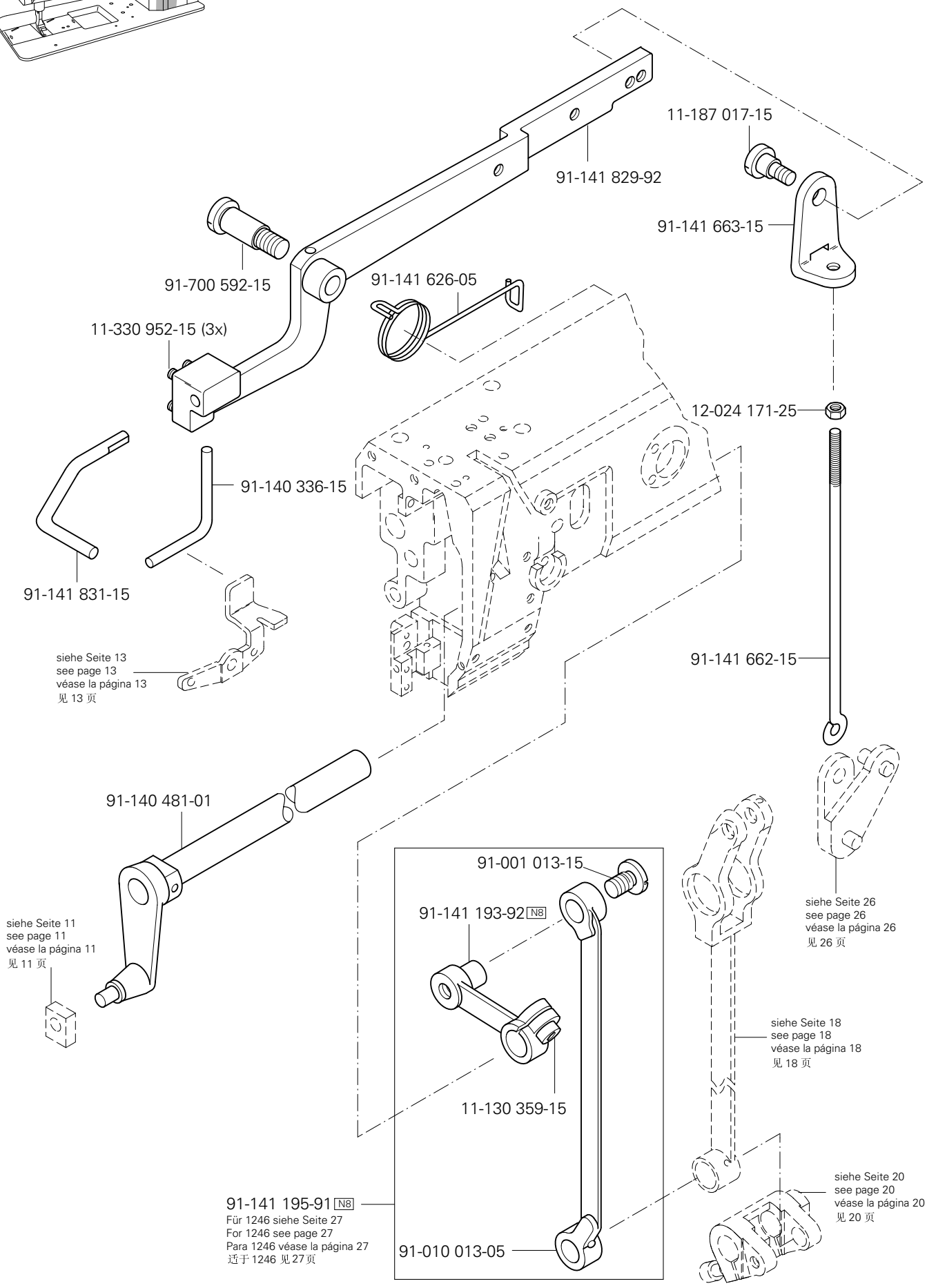

siehe Seite 13
 see page 13
 véase la página 13
 见 13 页

siehe Seite 11
 see page 11
 véase la página 11
 见 11 页

siehe Seite 26
 see page 26
 véase la página 26
 见 26 页

siehe Seite 18
 see page 18
 véase la página 18
 见 18 页

siehe Seite 20
 see page 20
 véase la página 20
 见 20 页

Für 1246 siehe Seite 27
 For 1246 see page 27
 Para 1246 véase la página 27
 适于 1246 见 27 页

3.03

Armteile Arm parts Piezas del brazo 机臂零件

PFAFF 1245

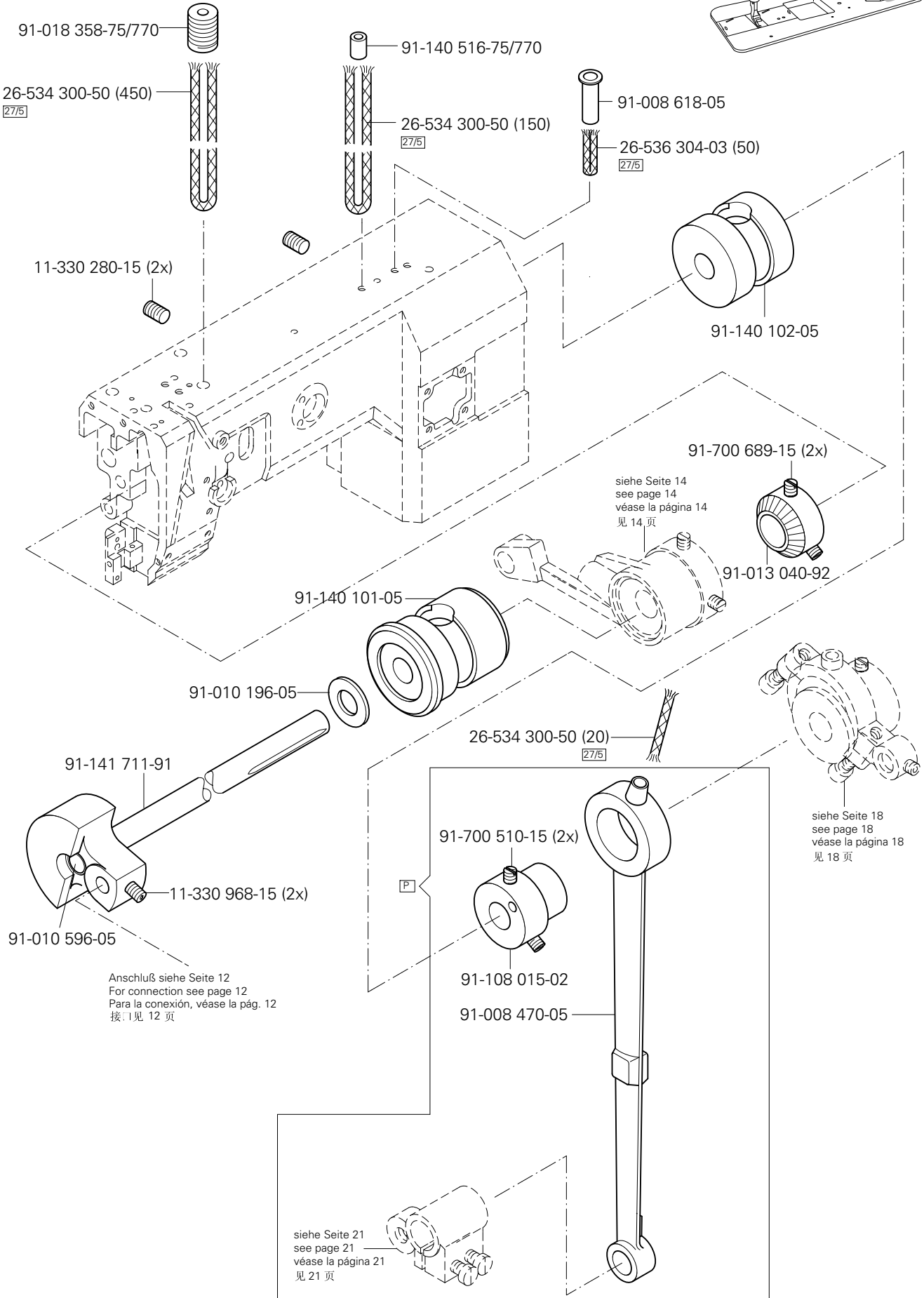
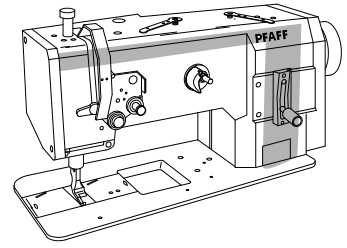

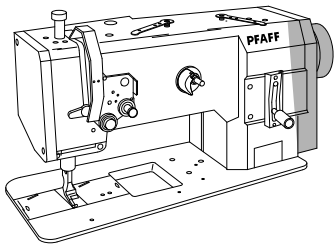

Armteile
 Arm parts
 Piezas del brazo
 机臂零件

PFAFF 1245

3.03

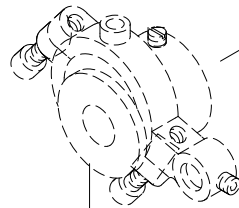
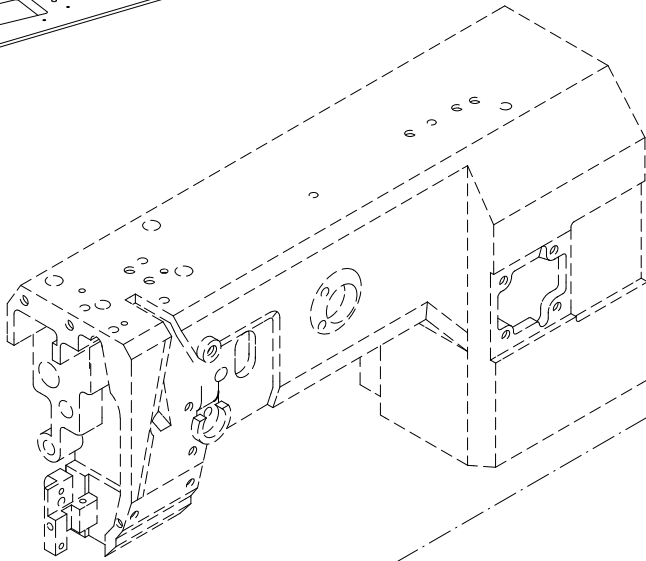

siehe Seite 18
 see page 18
 véase la página 18
 见 18 页

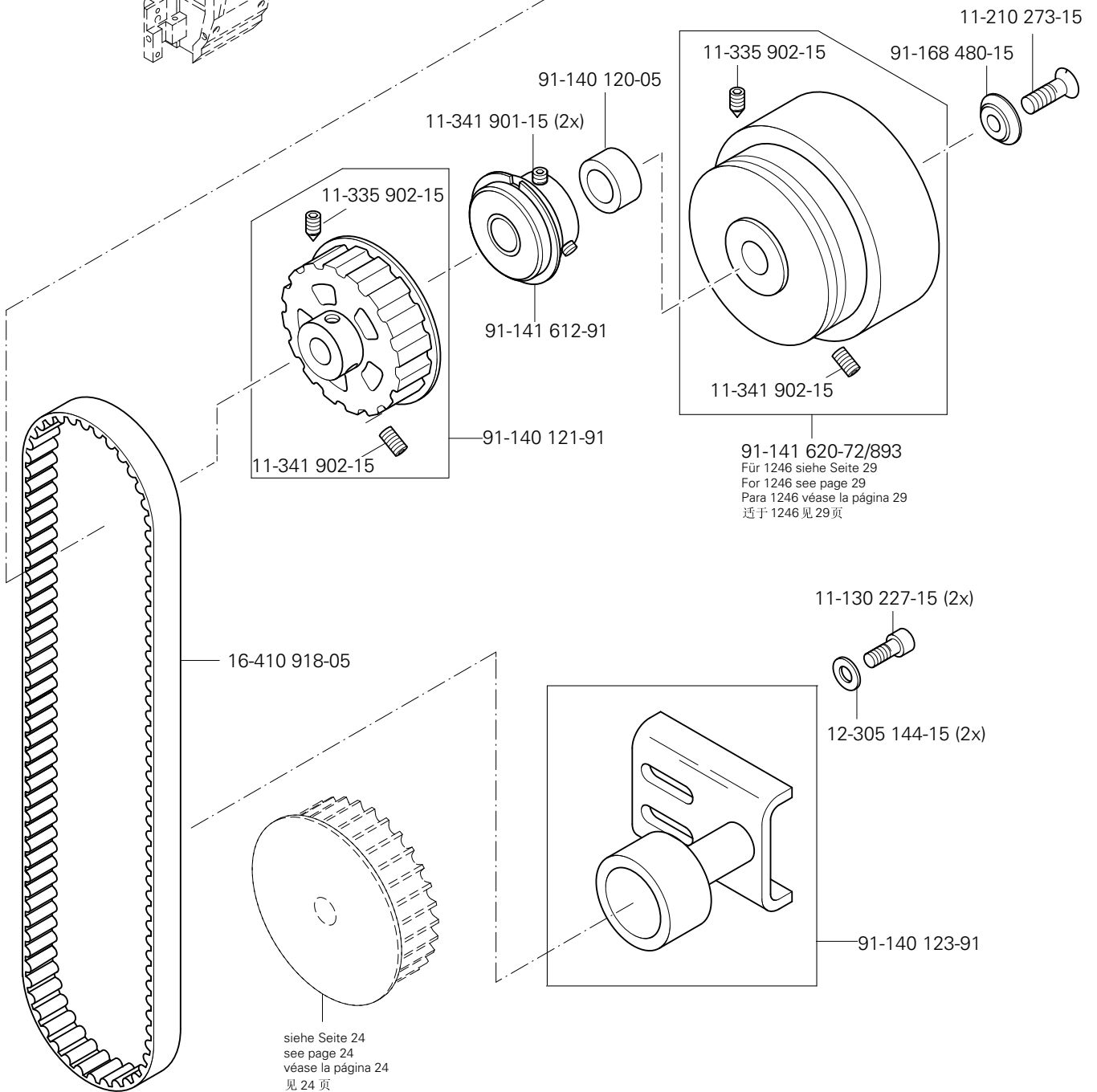

3.03

Armteile Arm parts Piezas del brazo 机臂零件

PFAFF 1245

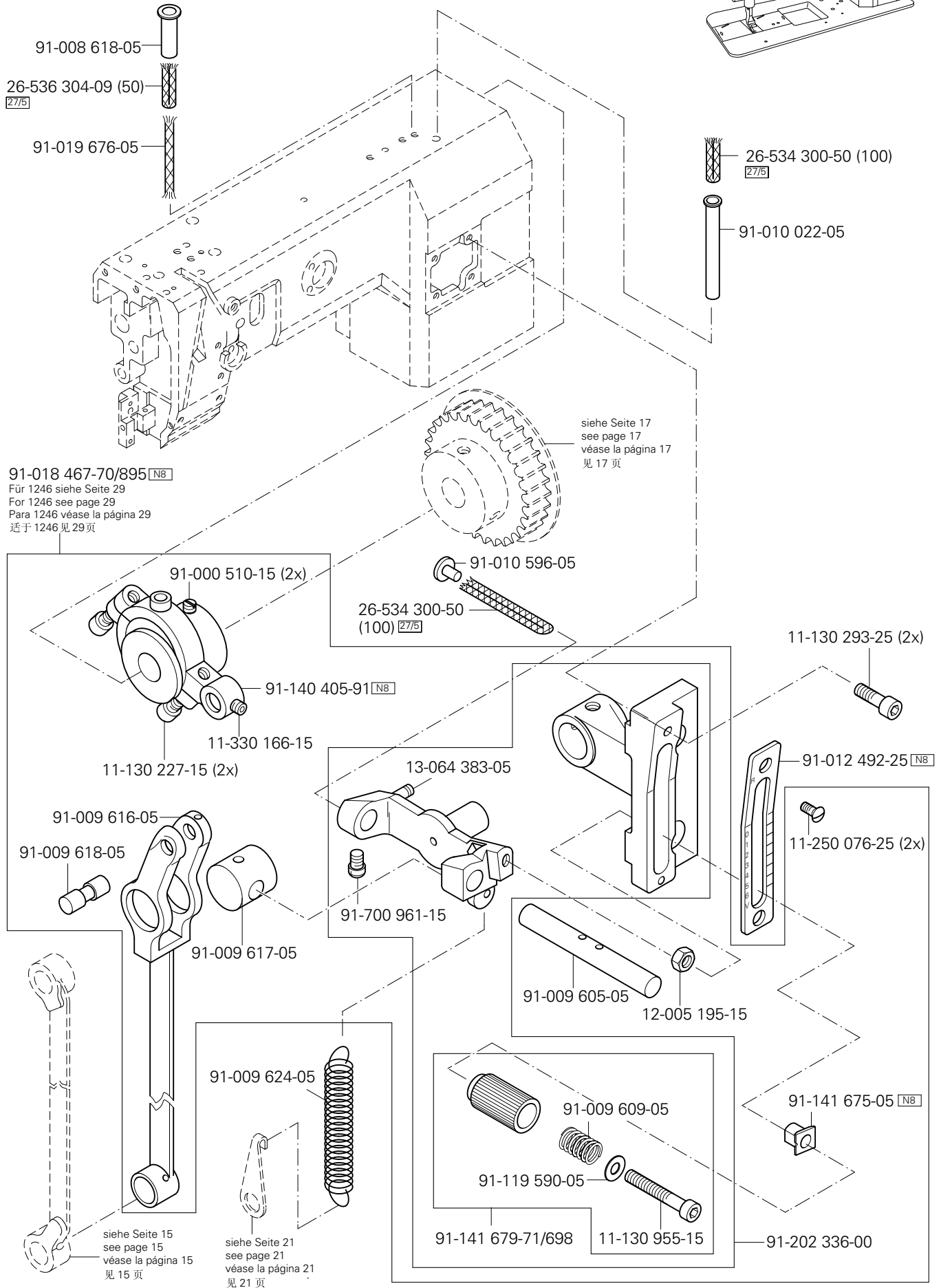
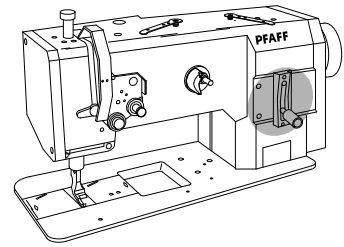

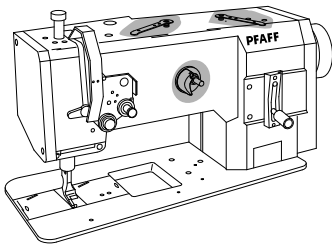

Armteile
 Arm parts
 Piezas del brazo
 机臂零件

PFAFF 1245

3.03

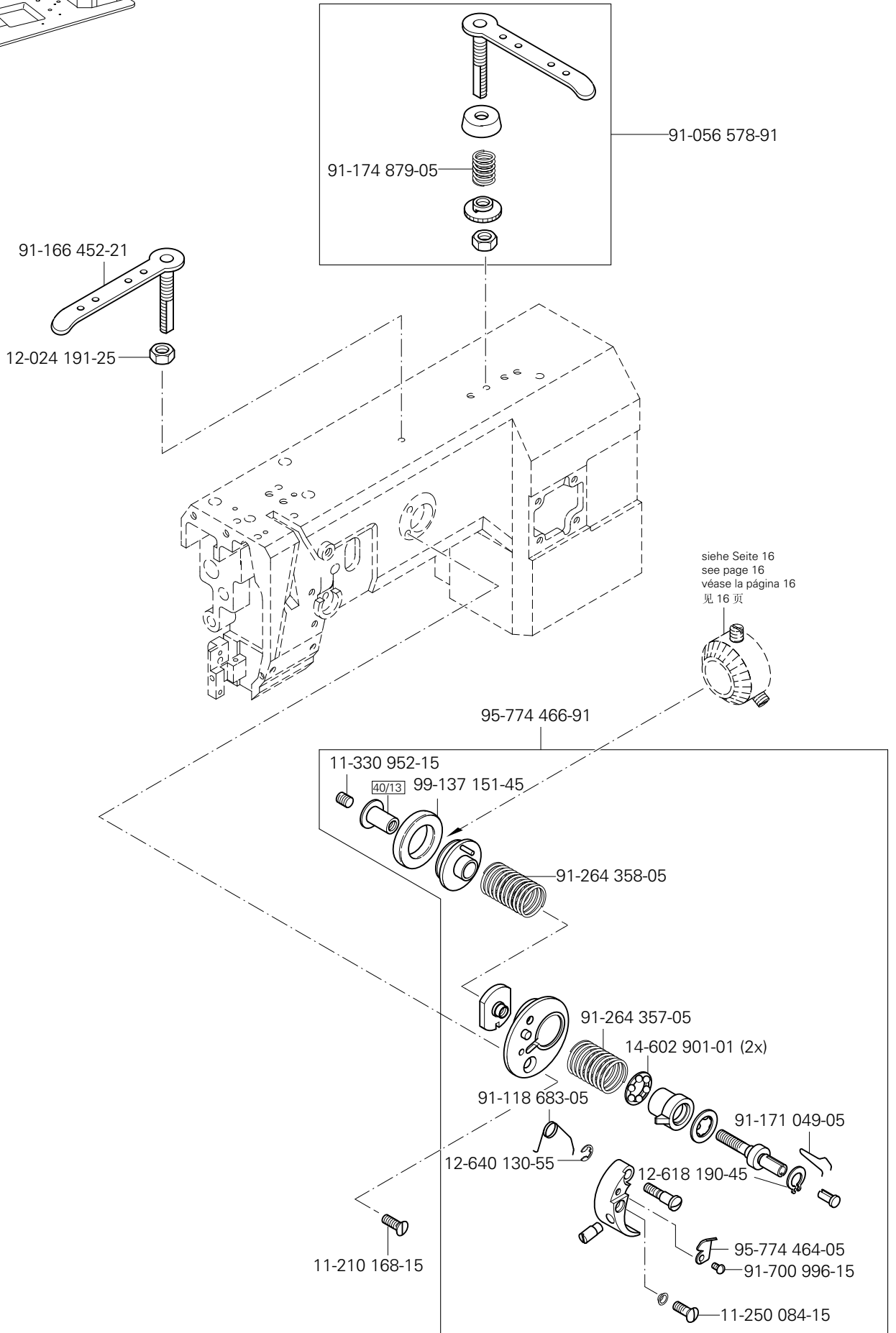

☐ siehe Kapitel 2 Erläuterung der Schlüsselzeichen
 see chapter 2 Explanation of key markings
 véase el Cap. 2 Explicaciones de los signos clave
 见第2章标记说明

3.04

Grundplattenteile Bedplate parts Piezas del cárter 底板零件

PFAFF 1245

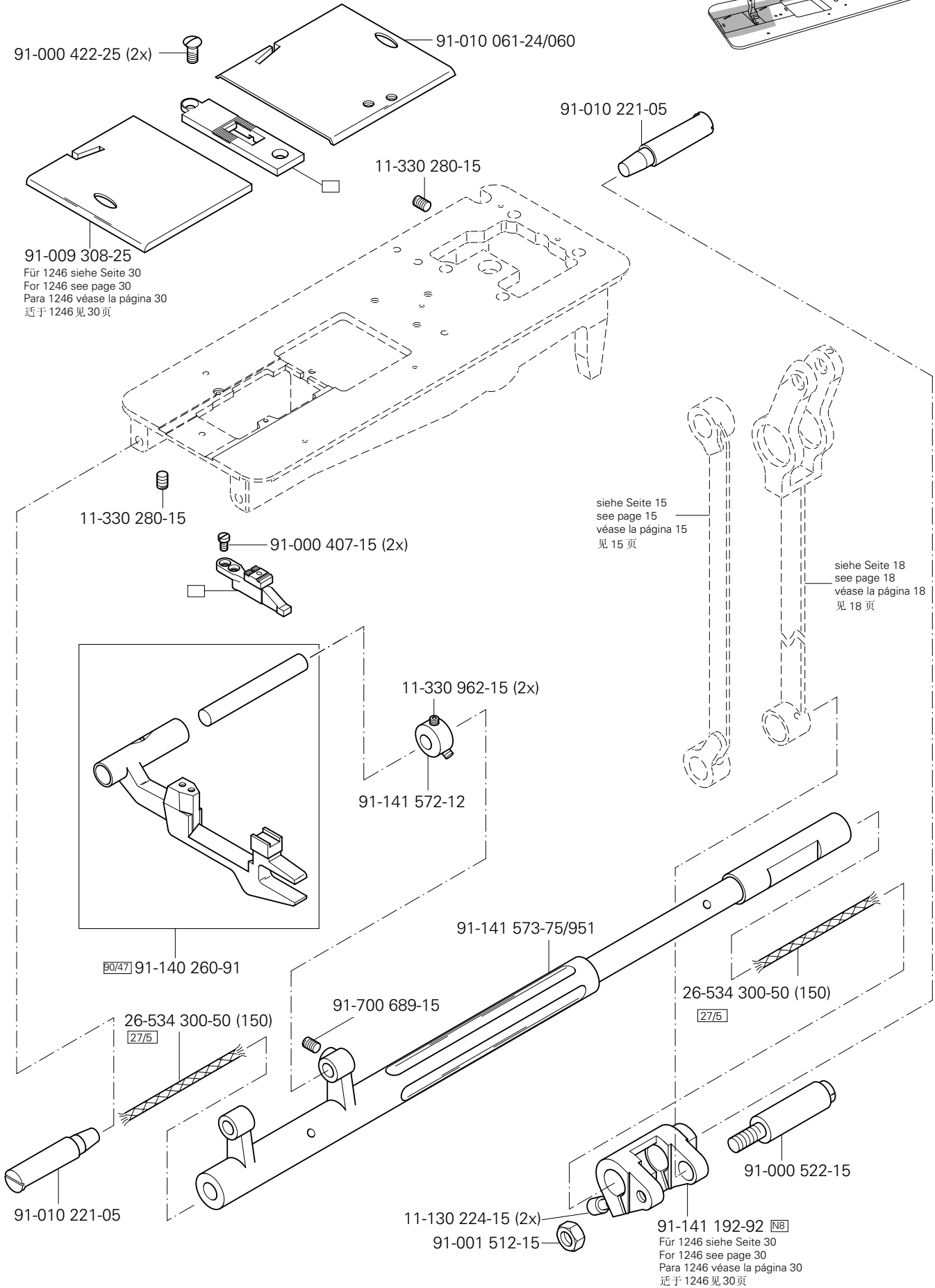
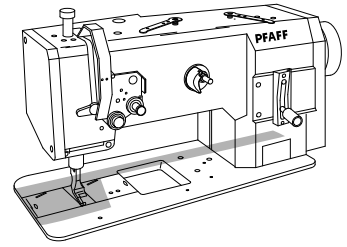

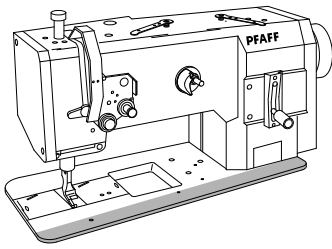

Grundplattenteile
Bedplate parts
Piezas del cárter
底板零件

PFAFF 1245

3.04

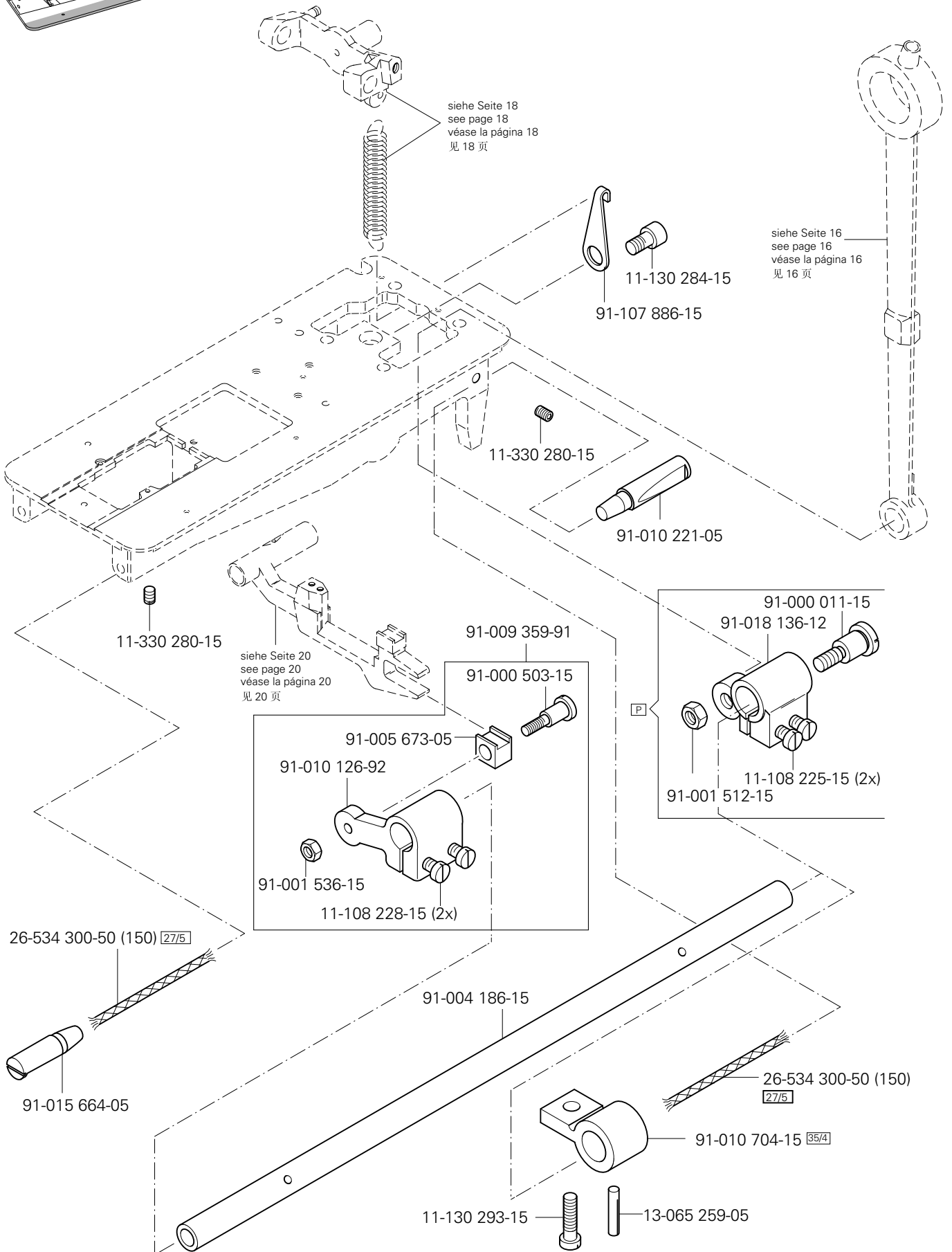

3.04

Grundplattenteile
Bedplate parts
Piezas del cárter
底板零件

PFAFF 1245

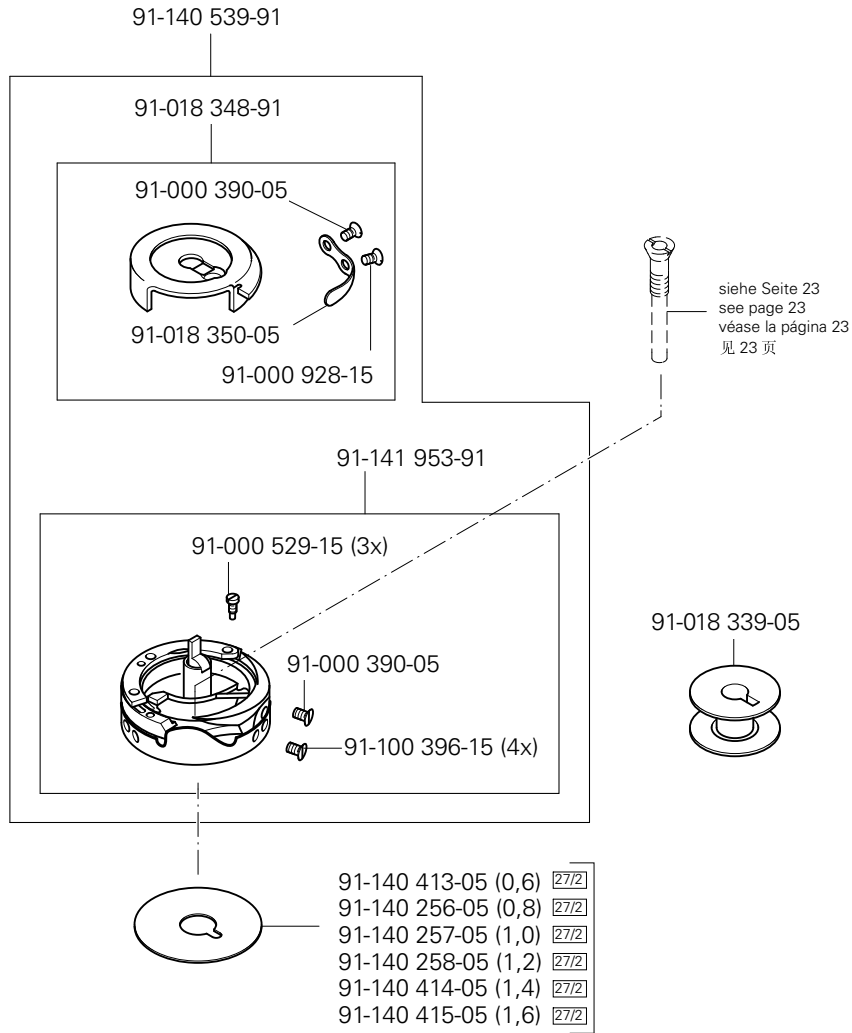
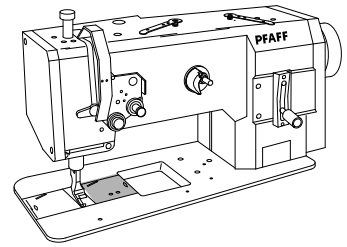

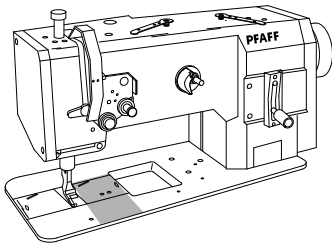

Grundplattenteile
Bedplate parts
Piezas del cárter
底板零件

PFAFF 1245

3.04

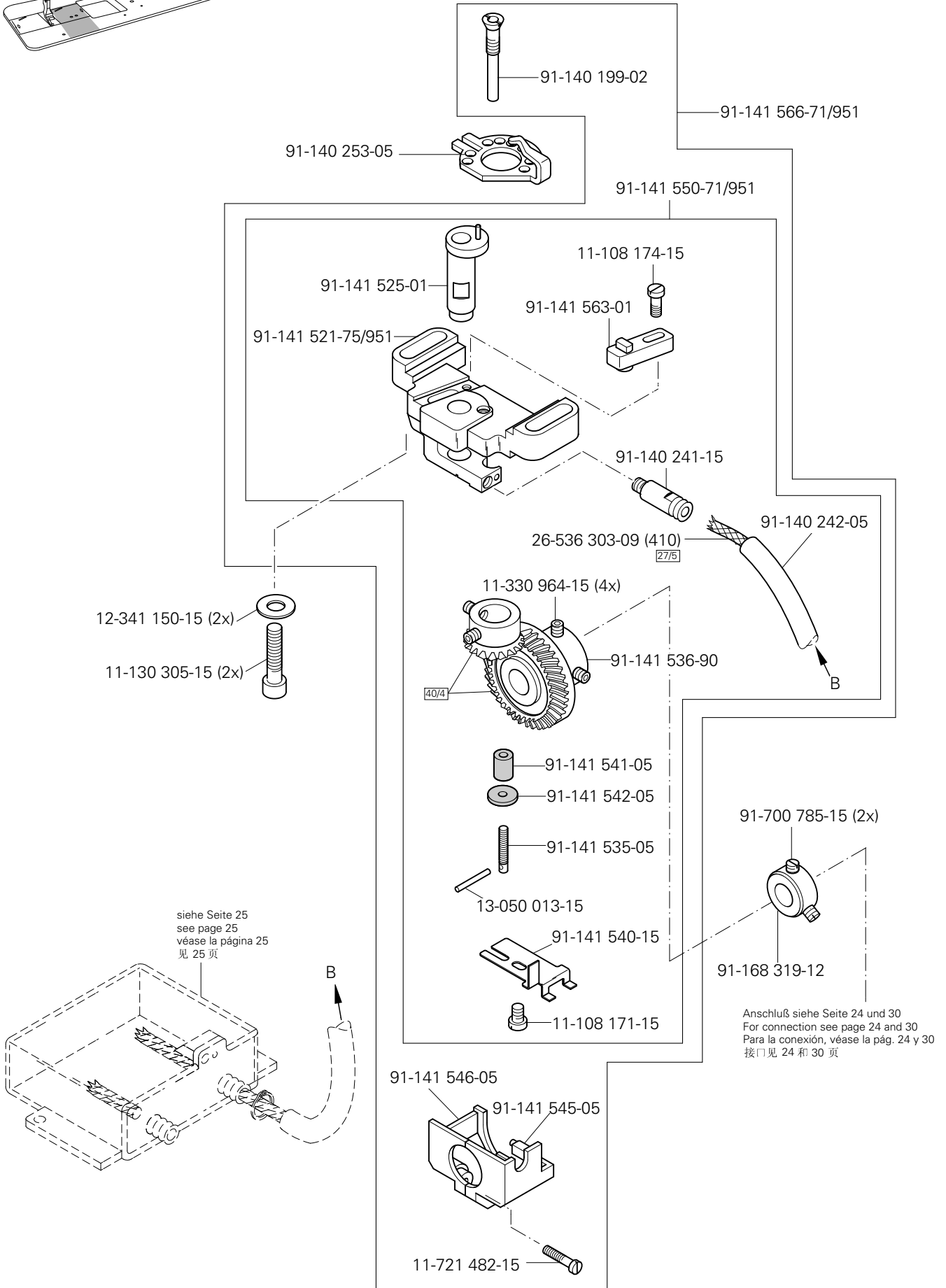

3.04

Grundplattenteile
Bedplate parts
Piezas del cárter
底板零件

PFAFF 1245

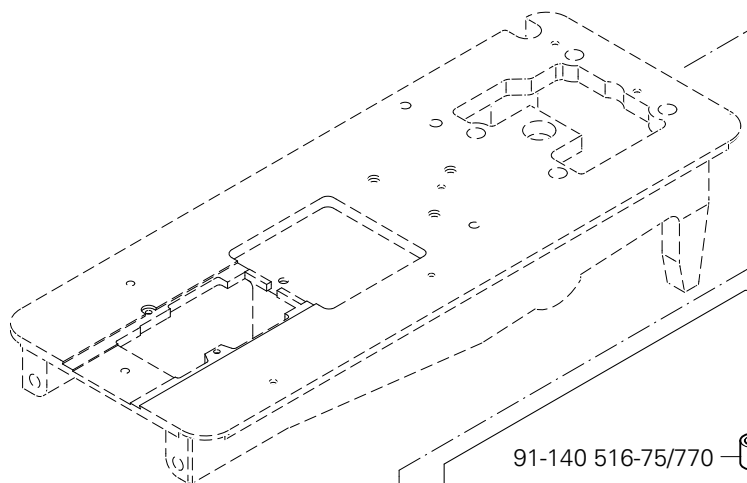
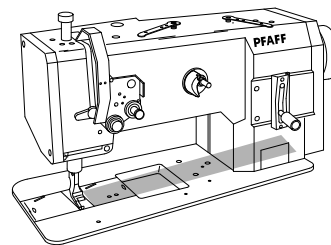

Für 1246 siehe Seite 30
For 1246 see page 30
Para 1246 véase la página 30
适于 1246 见 30 页

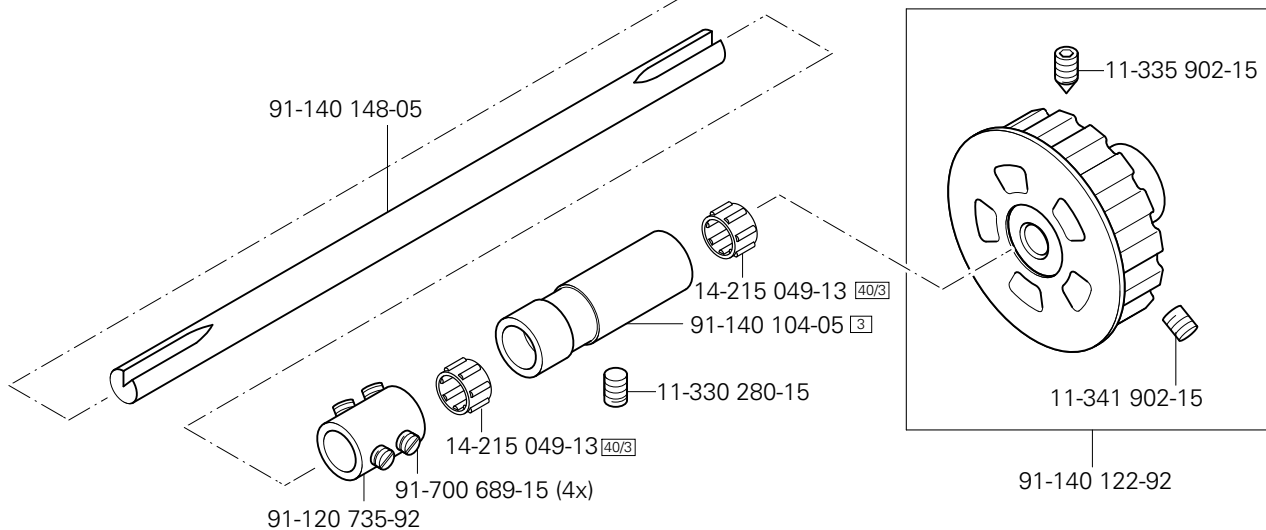
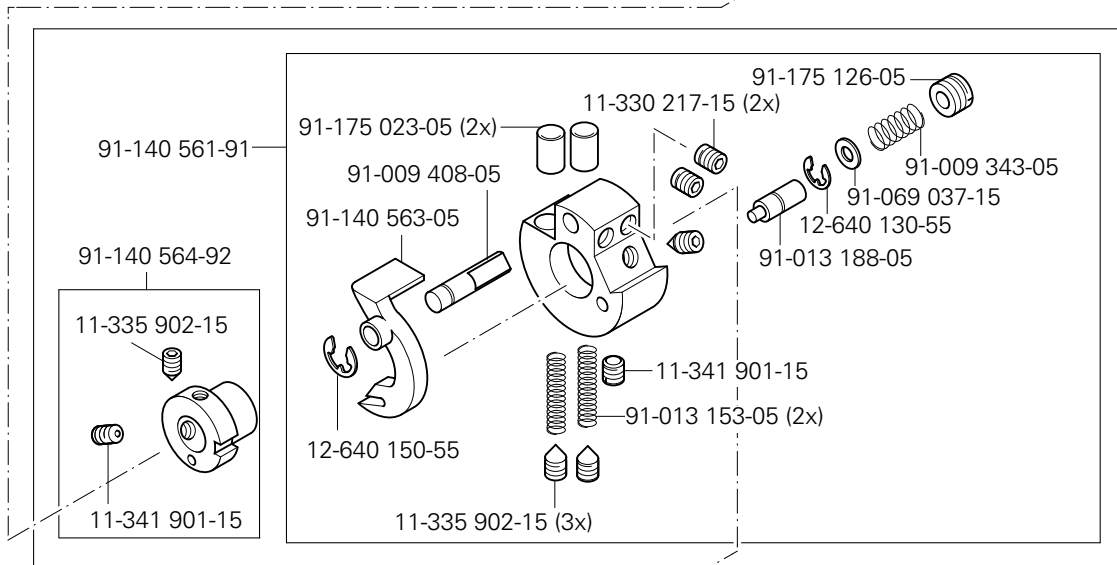
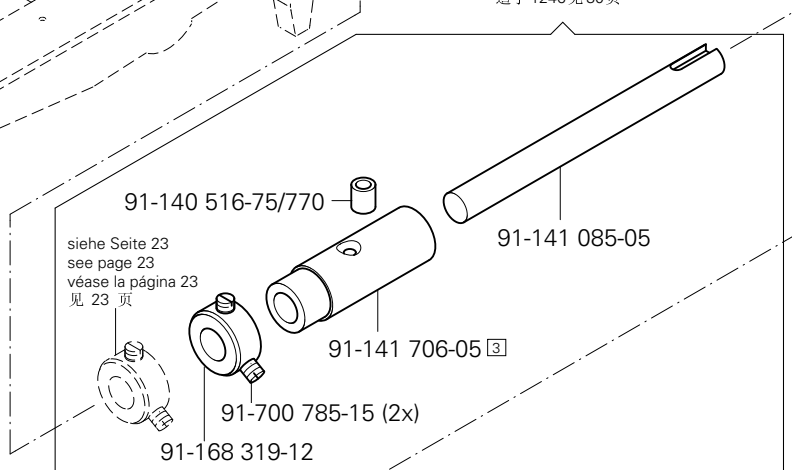

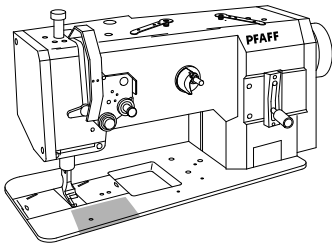

Grundplattenteile
Bedplate parts
Piezas del cárter
底板零件

PFAFF 1245

3.04

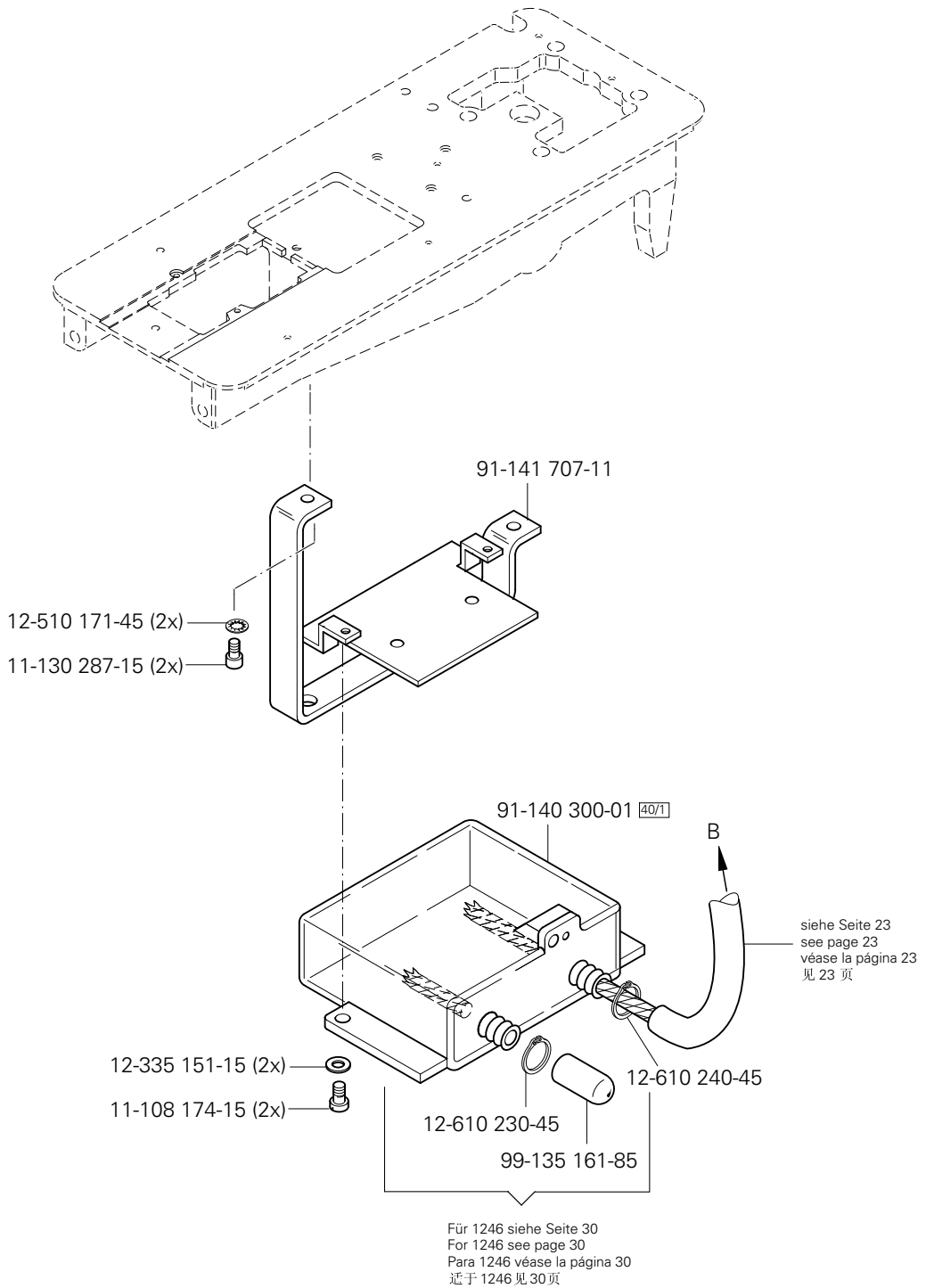

3.04

Grundplattenteile Bedplate parts Piezas del cárter 底板零件

PFAFF 1245

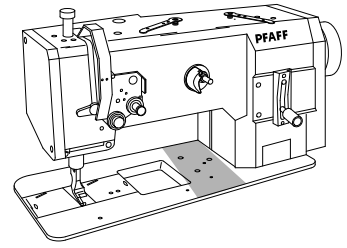

siehe Seite 15
see page 15
véase la página 15
见 15 页

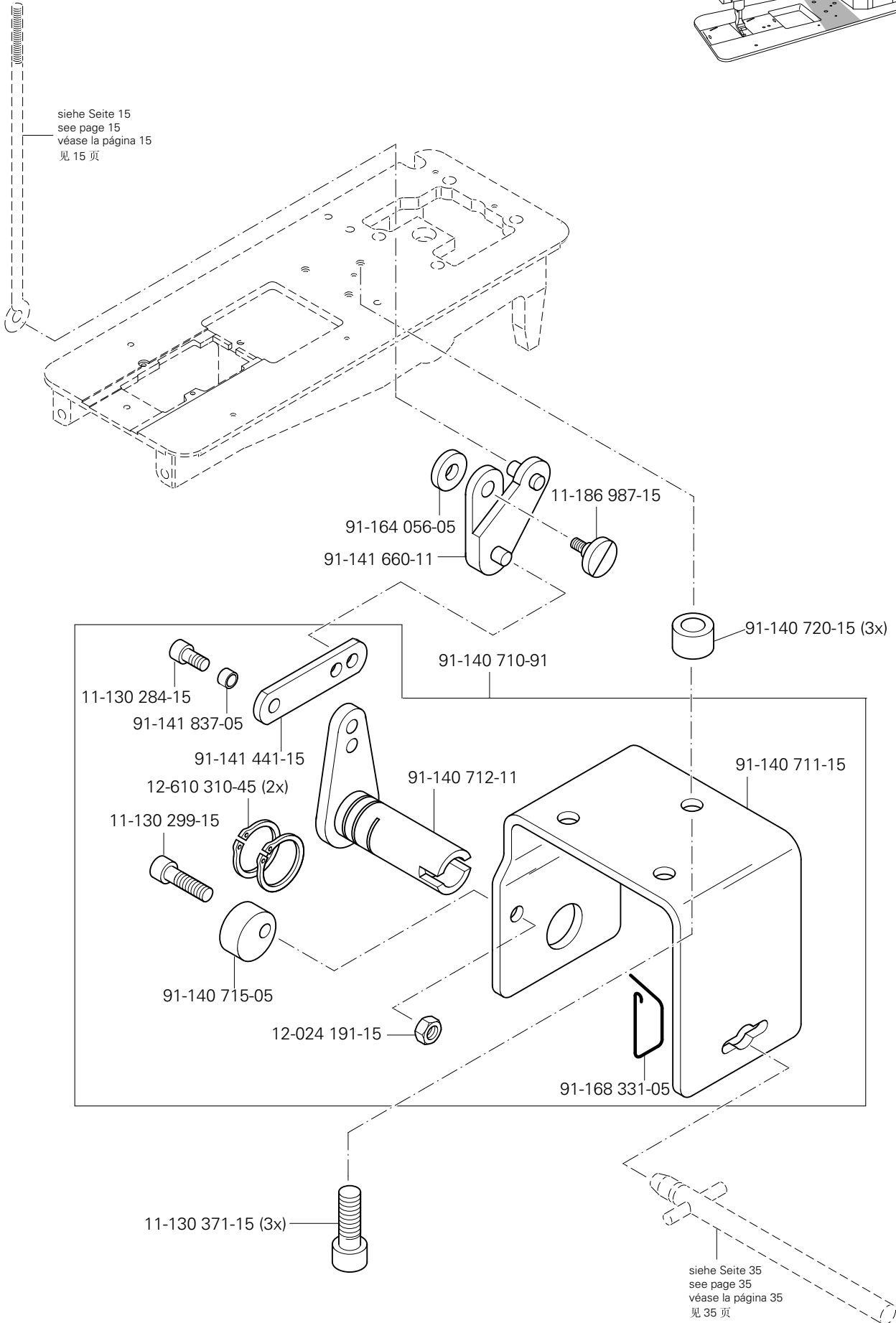

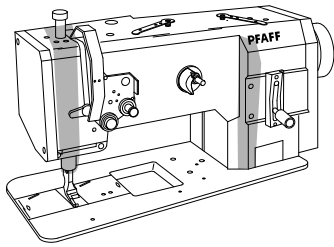

Abweichende Teile der PFAFF 1246
 Different parts for PFAFF 1246
 Piezas de la PFAFF 1246 que son diferentes
 PFAFF 1246 中有差别的零件

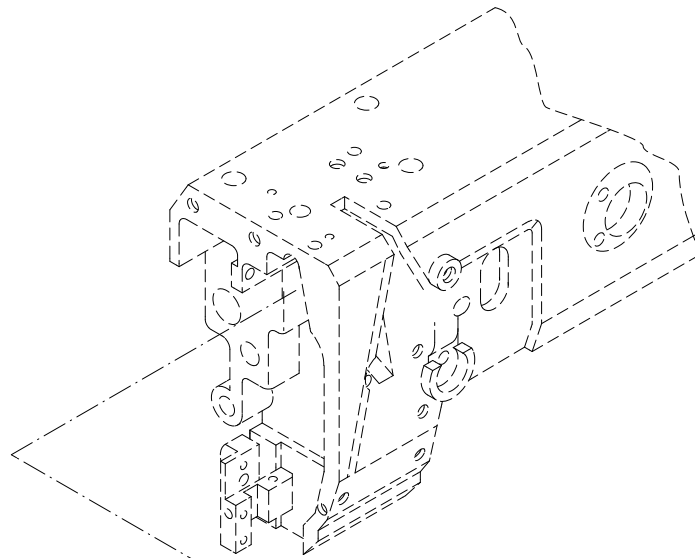

siehe Seite 10
 see page 10
 véase la página 10
 见 10 页

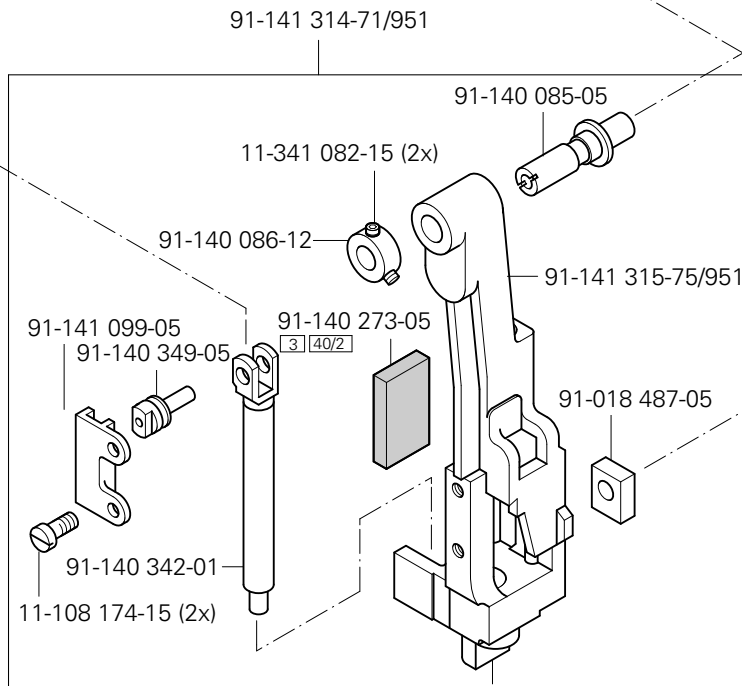

siehe Seite 15
 see page 15
 véase la página 15
 见 15 页

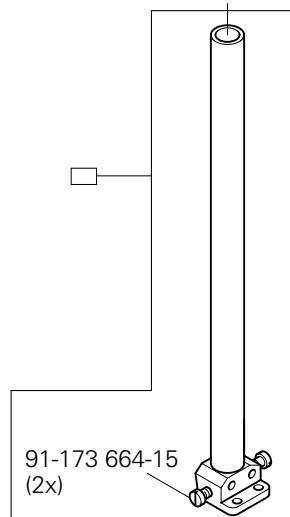
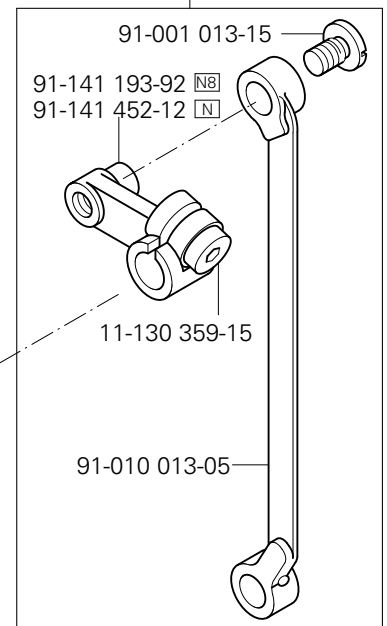
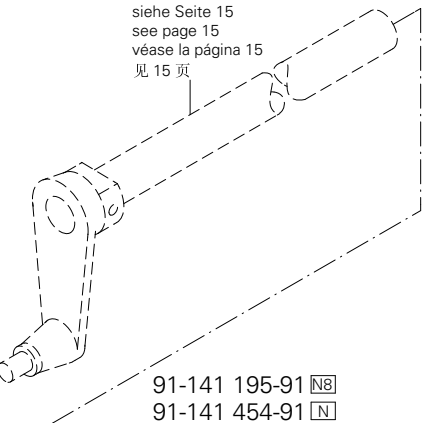

siehe Kapitel 2 Erläuterung der Schlüsselzeichen
 see chapter 2 Explanation of key markings
 véase el Cap. 2 Explicaciones de los signos clave
 见第2章标记说明

(die sonstigen Teile wie in Register 3.01 bis 3.04)
 (for all other parts see Sections 3.01 to 3.04)
 (las demás piezas como en los registros 3.01 al 3.04)
 (其它零件与3.01至3.04 章中的相同)

4

Abweichende Teile der PFAFF 1246
 Different parts for PFAFF 1246
 Piezas de la PFAFF 1246 que son diferentes
 PFAFF 1246 中有差别的零件

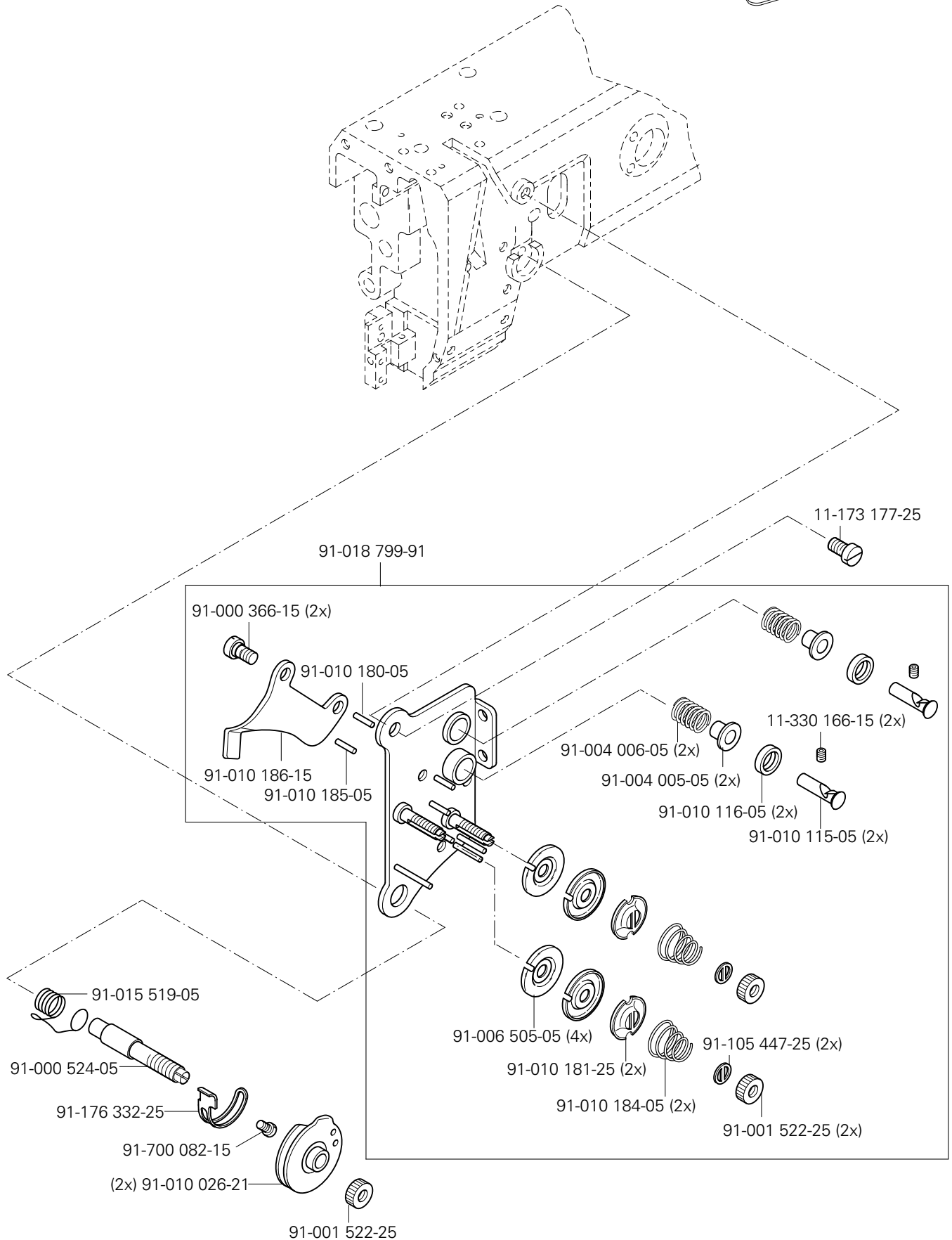
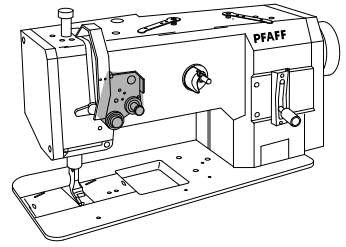

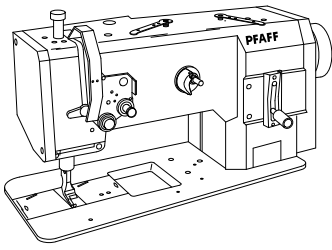

Abweichende Teile der PFAFF 1246
 Different parts for PFAFF 1246
 Piezas de la PFAFF 1246 que son diferentes
 PFAFF 1246 中有差别的零件

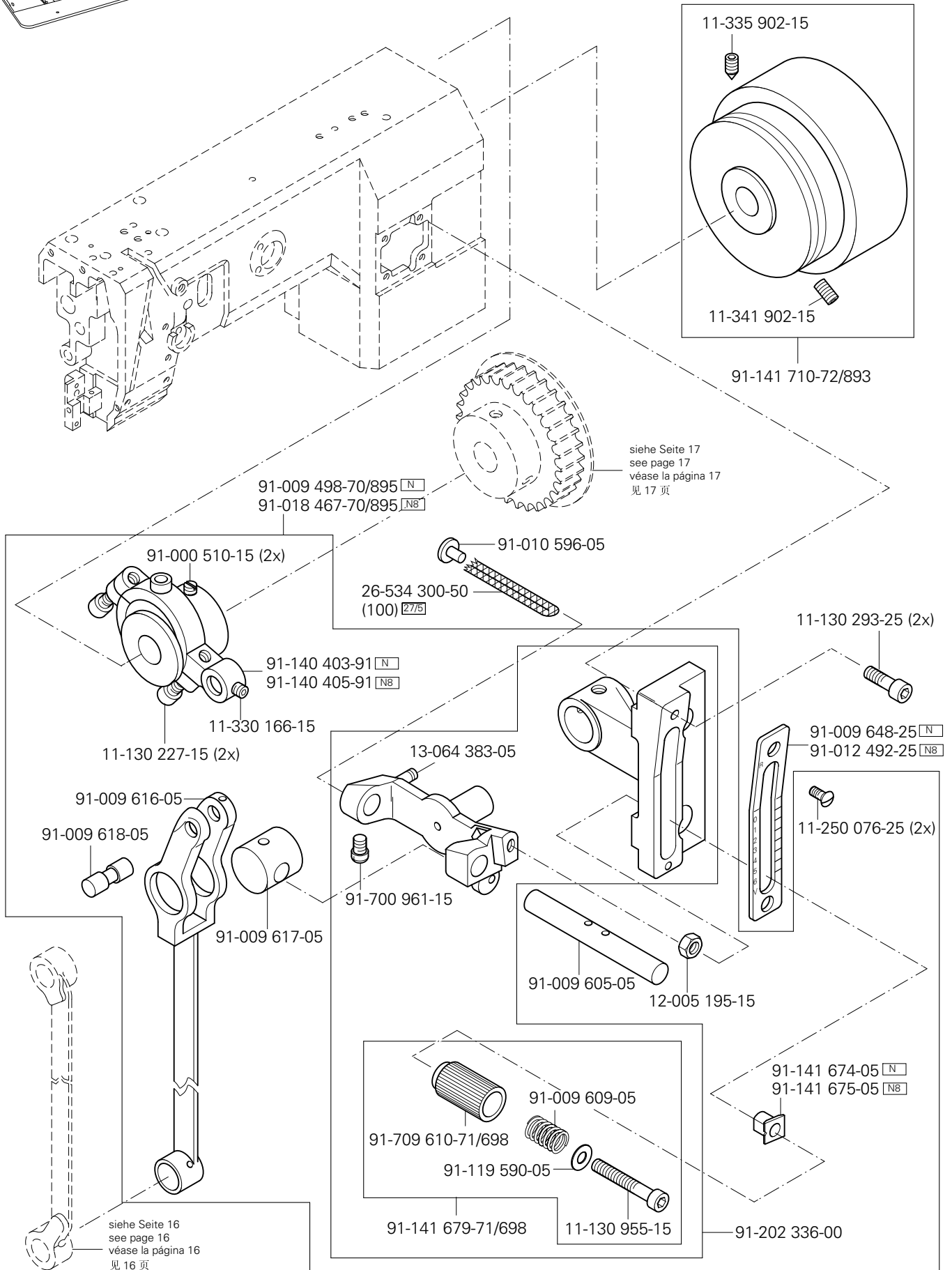

N siehe Kapitel 2 Erläuterung der Schlüsselzeichen
 see chapter 2 Explanation of key markings
 véase el Cap. 2 Explicaciones de los signos clave
 见第2章标记说明

(die sonstigen Teile wie in Register 3.01 bis 3.04)
 (for all other parts see Sections 3.01 to 3.04)
 (las demás piezas como en los registros 3.01 al 3.04)
 (其它零件与3.01至3.04 章中的相同)

4

Abweichende Teile der PFAFF 1246 Different parts for PFAFF 1246 Piezas de la PFAFF 1246 que son diferentes PFAFF 1246 中有差别的零件

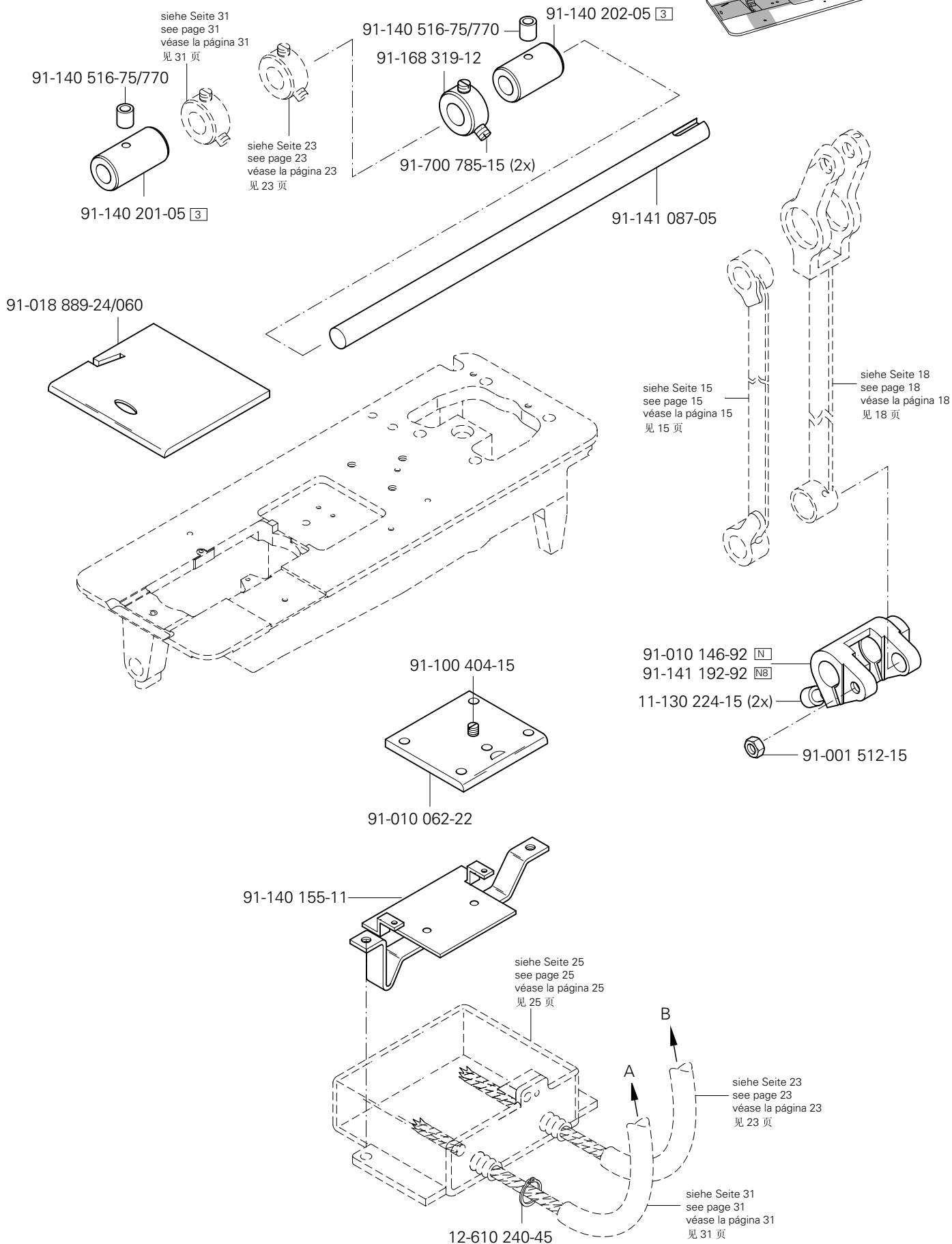
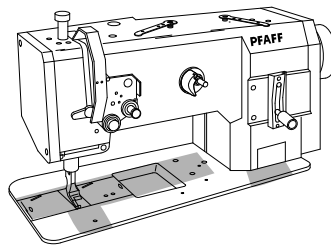

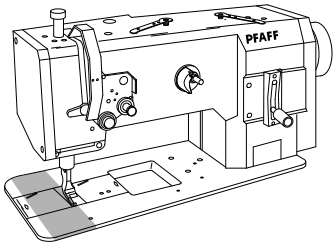

Abweichende Teile der PFAFF 1246
 Different parts for PFAFF 1246
 Piezas de la PFAFF 1246 que son diferentes
 PFAFF 1246 中有差别的零件

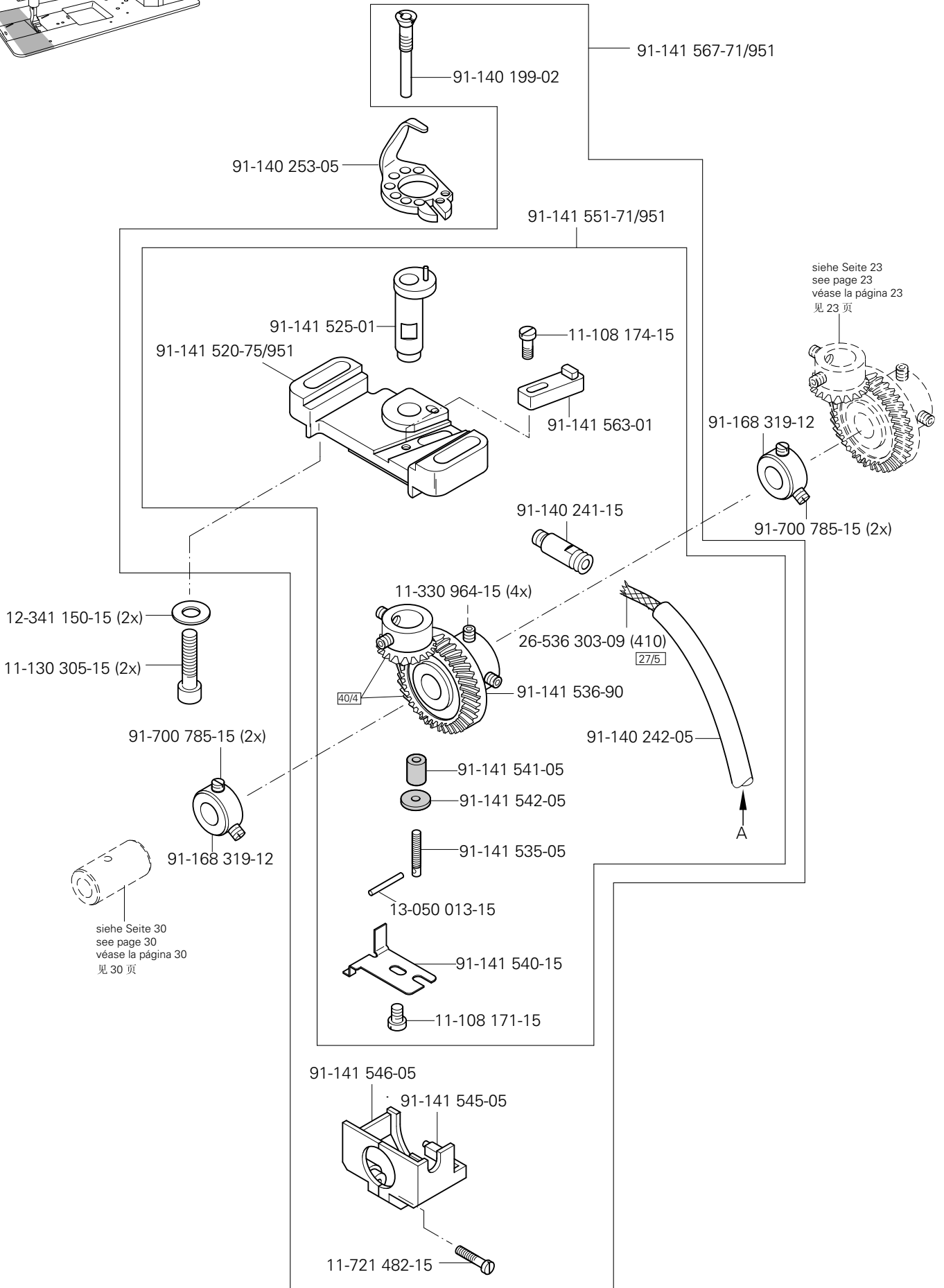

☐ siehe Kapitel 2 Erläuterung der Schlüsselzeichen
 see chapter 2 Explanation of key markings
 véase el Cap. 2 Explicaciones de los signos clave
 见第2章标记说明

(die sonstigen Teile wie in Register 3.01 bis 3.04)
 (for all other parts see Sections 3.01 to 3.04)
 (las demás piezas como en los registros 3.01 al 3.04)
 (其它零件与3.01至3.04 章中的相同)

5

Nähfuß heben über Pedal (-910/01)
 Raiser presser foot via the pedal (-910/01)
 Elevación del prensatelas mediante pedal (-910/01)
 用踏板抬起压脚 (-910/01)

PFAFF 1245

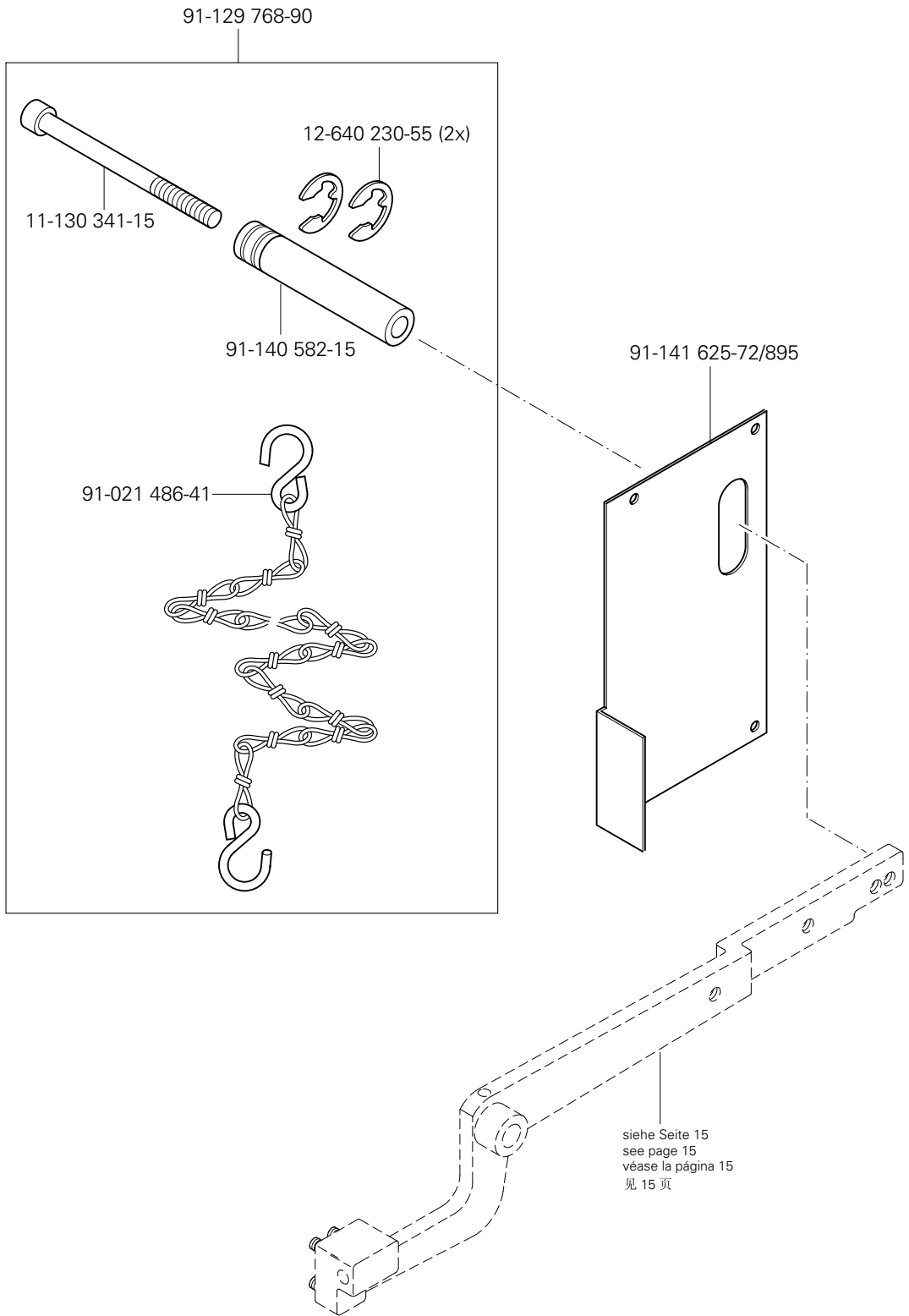
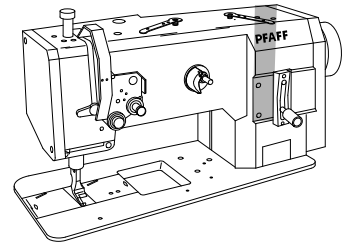

91-229 070-70/895

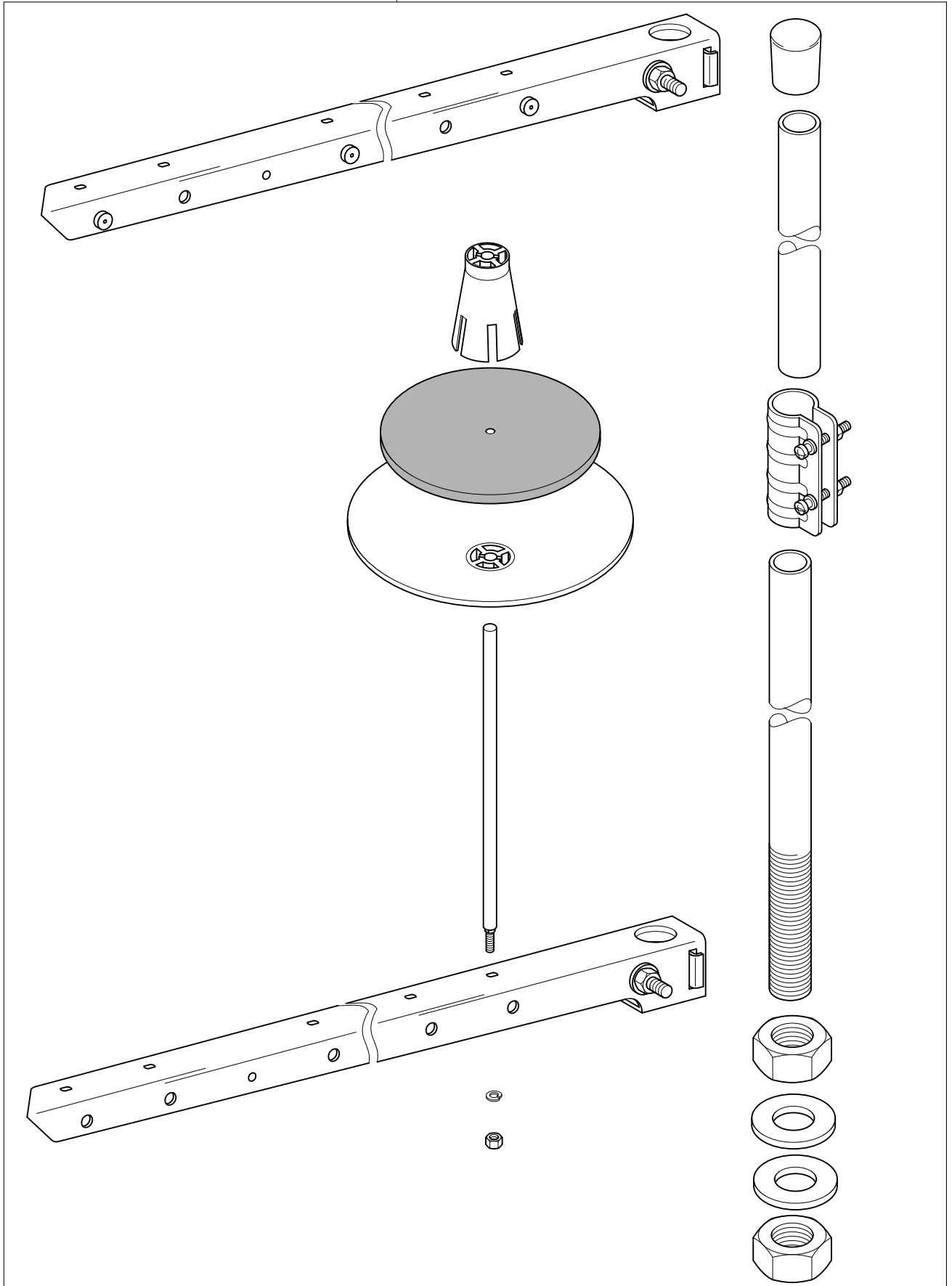

7

Einstellehren
Adjustment gauges
Calibres de ajuste
设置量规

PFAFF 1245
PFAFF 1246

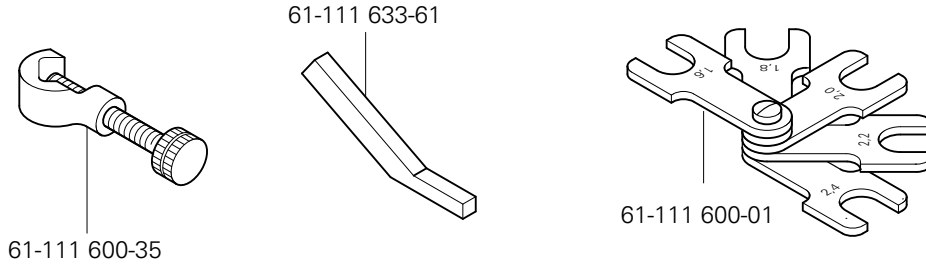

8

Teile zur Tischplatte
Parts for table top
Piezas para el tablero
用于台板的零件

PFAFF 1245
PFAFF 1246

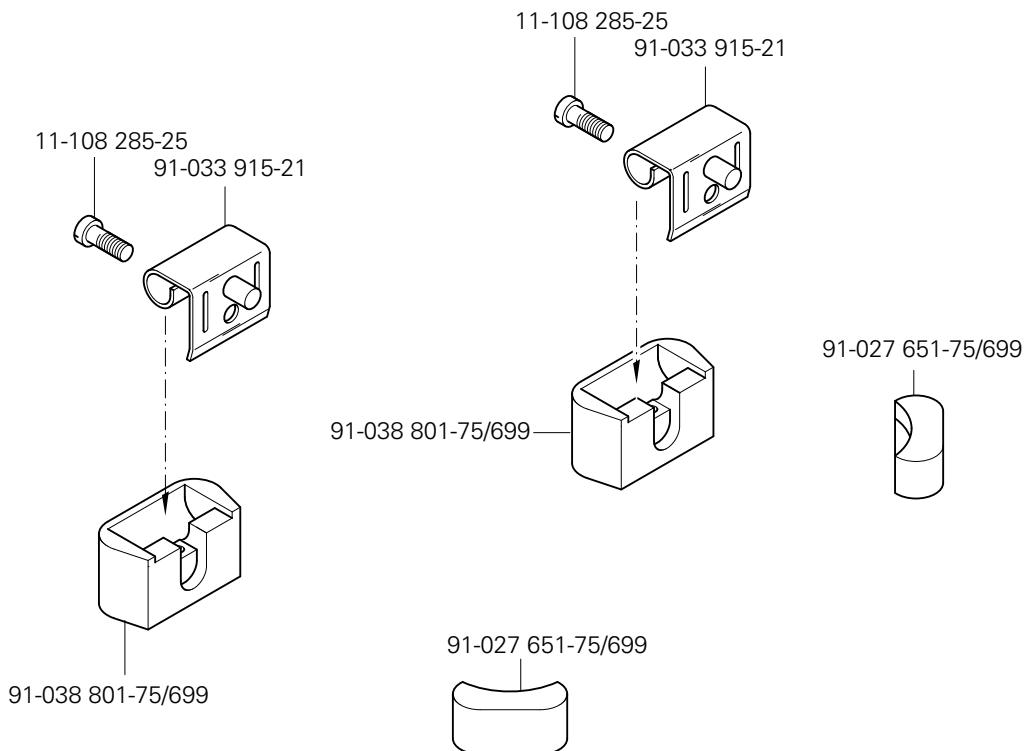

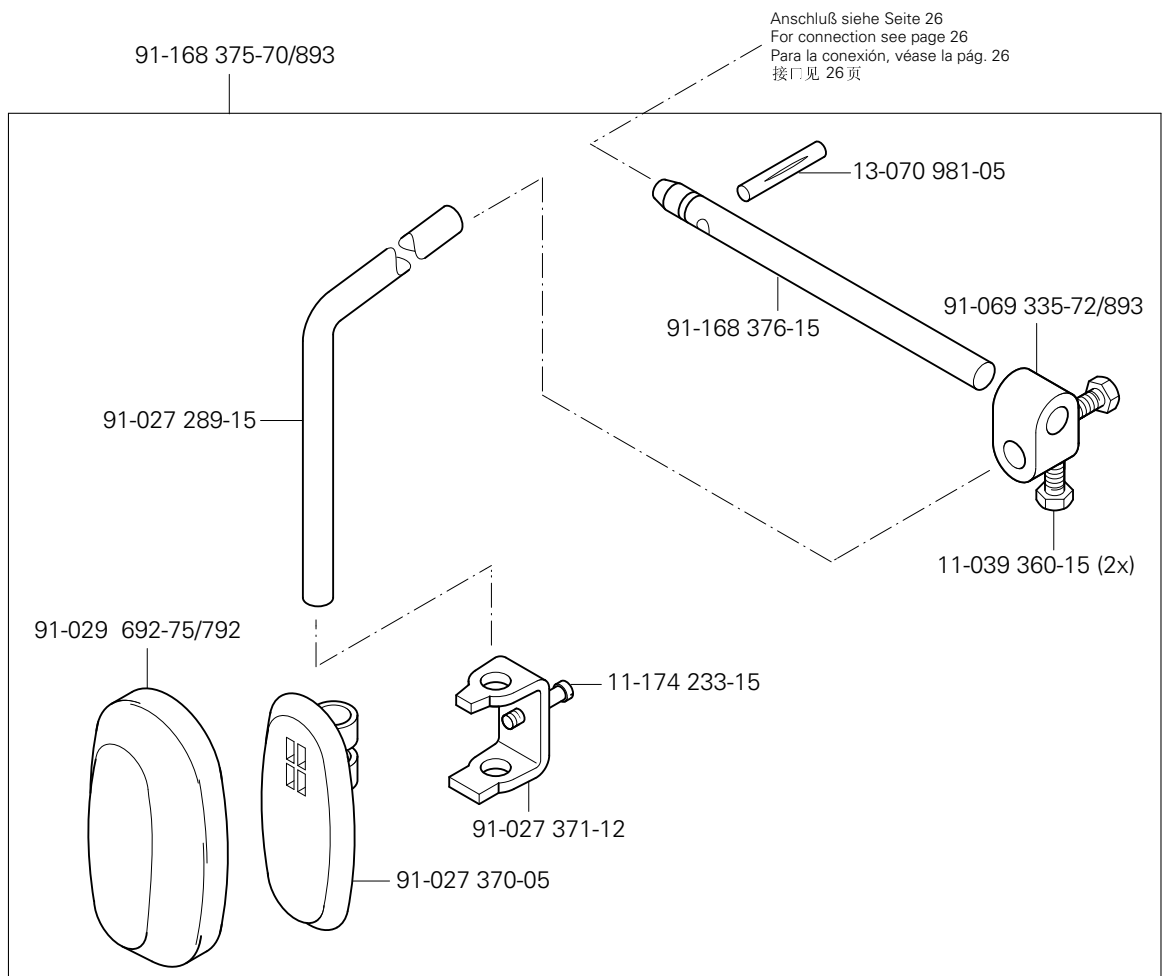
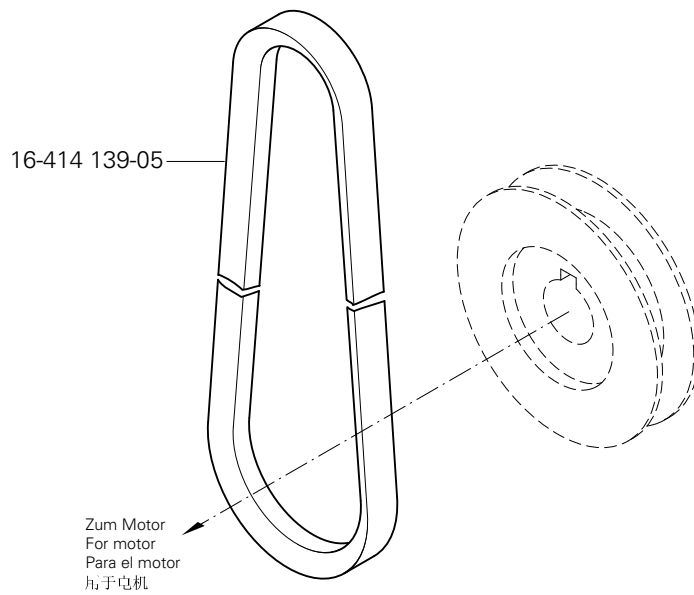

| Öl Oil Aceite 油 | Mittelpunkts-Viskosität bei: Mean viscosity at: Viscosidad media a: 中点粘度: | | Dichte bei: Density of: Densidad a: 密度, 在: | | Bestellnummer für Behälter mit: Part number for can with: Número de pedido para recipientes con: 订货号用于油箱, 带: | | |
|--------------------------|--|--------------------|---|-----------------------------|---|--|--|
| | °C | mm ² /s | °C | g/cm ³ (g/ml) | 1 Liter 1 Litre 1 Litro 1 升 | | |
| 28-011 201-44 | 40 | 22,0 | 15 | 0,865 | 91-129 917-91 | | |
| | | | | | | | |
| | | | | | | | |
| | | | | | | | |

| Fett Grease Grasa 脂 | Penetration Penetration Penetración 贯入度 | Tropfpunkt Drip-point Punto de goteo 贯入度 | Bestellnummer für Behälter mit: Part number for can with: Número de pedido para recipientes con: 订货号用于油箱, 带: | | |
|------------------------------|--|---|---|----|---------------|
| | | | mm/10 | °C | 0,25 kg |
| 28-011 202-05 | | | | | 28-011 205-05 |
| 28-011 202-43 | 375-405 | 150 | | | 28-011 202-43 |
| 28-011 202-47 | 220-250 | 185 | | | 28-011 202-47 |
| | | | | | |

| Reinigungsmittel Cleansing agent Limpiadores 清洁剂 | Bestellnummer für Behälter mit: Part number for can with: Número de pedido para recipientes con: 订货号用于油箱, 带: | | |
|---|---|--|--|
| | 240 ml | | |
| Isoprophyl-Alkohol / 异丙醇 | 95-665 735-91 | | |

| No. 零件号 | Seite Page Página 页号 | No. 零件号 | Seite Page Página 页号 | No. 零件号 | Seite Page Página 页号 | No. 零件号 | Seite Page Página 页号 |
|---------------|-------------------------------|---------------|----------------------------------|---------------|-------------------------------|-------------------|-------------------------------|
| 11-039 222-15 | 14 | 11-174 089-15 | 11 | 12-510 171-45 | 25 | 91-000 366-15 | 13, 28 |
| 11-039 225-15 | 14 | 11-174 173-15 | 10 | 12-610 170-45 | 10 | 91-000 390-05 | 22 |
| 11-039 360-15 | 35 | 11-174 233-15 | 13, 35 | 12-610 190-45 | 10 | 91-000 407-15 | 20 |
| 11-108 093-15 | 11 | 11-186 987-15 | 26 | 12-610 200-45 | 10 | 91-000 422-25 | 20 |
| 11-108 171-15 | 11, 23, 31 | 11-187 017-15 | 15 | 12-610 230-45 | 25 | 91-000 503-15 | 21 |
| 11-108 174-15 | 11, 23, 25, 27, 31 | 11-210 165-15 | 13 | 12-610 240-45 | 25, 30 | 91-000 510-15 | 18, 29 |
| 11-108 177-15 | 11 | 11-210 168-15 | 19 | 12-610 310-45 | 26 | 91-000 522-15 | 20 |
| 11-108 177-25 | 12 | 11-210 273-15 | 17 | 12-618 190-45 | 19 | 91-000 524-05 | 13, 28 |
| 11-108 222-15 | 11 | 11-250 076-25 | 18, 29 | 12-640 130-55 | 19, 24 | 91-000 529-15 | 22 |
| 11-108 225-15 | 9, 21 | 11-250 084-15 | 19 | 12-640 150-55 | 24 | 91-000 928-15 | 22 |
| 11-108 228-15 | 10, 14, 21 | 11-330 166-15 | 13, 18, 28, 29 | 12-640 170-55 | 13 | 91-001 013-15 | 15, 27 |
| 11-108 234-15 | 9 | 11-330 217-15 | 24 | 12-640 230-55 | 32 | 91-001 512-15 | 20, 21, 30 |
| 11-108 285-15 | 9 | 11-330 220-15 | 11, 13 | 13-050 013-15 | 23, 31 | 91-001 522-25 | 13, 28 |
| 11-108 285-25 | 34 | 11-330 280-15 | 10, 11, 12, 16, 20, 21, 24 | 13-064 383-05 | 13, 18, 29 | 91-001 536-15 | 21 |
| 11-130 173-15 | 11 | 11-330 952-15 | 15, 19 | 13-065 259-05 | 21 | 91-003 113-05 | 9 |
| 11-130 185-15 | 11 | 11-330 962-15 | 20 | 13-070 981-05 | 35 | 91-004 005-05 | 13, 28 |
| 11-130 224-15 | 11, 20, 30 | 11-330 964-15 | 23, 31 | 14-215 049-13 | 24 | 91-004 006-05 | 13, 28 |
| 11-130 227-15 | 17, 18, 29 | 11-330 968-15 | 14, 16 | 14-602 901-01 | 19 | 91-004 186-15 | 21 |
| 11-130 254-15 | 9 | 11-335 902-15 | 17, 24, 29 | 15-711 050-51 | 14 | 91-004 309-05 | 10 |
| 11-130 284-15 | 21, 26 | 11-341 082-15 | 11, 27 | 16-410 918-05 | 17 | 91-005 673-05 | 21 |
| 11-130 287-15 | 25 | 11-341 901-15 | 17, 24 | 16-414 139-05 | 35 | 91-006 505-05 | 13, 28 |
| 11-130 293-15 | 21 | 11-341 902-15 | 17, 24, 29 | 26-534 300-50 | 12, 16, 18, 20, 21, 29 | 91-008 470-05 | 16 |
| 11-130 293-25 | 18, 29 | 11-462 118-55 | 9 | 26-536 303-09 | 23, 31 | 91-008 618-05 | 16, 18 |
| 11-130 299-15 | 26 | 11-721 482-15 | 23, 31 | 26-536 304-03 | 16 | 91-009 308-25 | 20 |
| 11-130 305-15 | 23, 31 | 12-005 195-15 | 18, 29 | 26-536 304-09 | 12, 18 | 91-009 343-05 | 24 |
| 11-130 341-15 | 32 | 12-024 171-25 | 15 | 28-011 201-44 | 36 | 91-009 359-91 | 21 |
| 11-130 359-15 | 15, 27 | 12-024 191-15 | 26 | 28-011 202-05 | 36 | 91-009 408-05 | 24 |
| 11-130 371-15 | 26 | 12-024 191-25 | 19 | 28-011 202-43 | 36 | 91-009 498-70/895 | 29 |
| 11-130 906-15 | 9 | 12-305 114-15 | 11 | 28-011 202-47 | 36 | 91-009 605-05 | 18, 29 |
| 11-130 955-15 | 18, 29 | 12-305 144-15 | 11, 17 | 61-111 600-01 | 34 | 91-009 609-05 | 18, 29 |
| 11-173 171-75 | 9 | 12-335 151-15 | 25 | 61-111 600-35 | 34 | 91-009 616-05 | 18, 29 |
| 11-173 177-25 | 13, 28 | 12-335 171-15 | 14 | 61-111 633-61 | 34 | 91-009 617-05 | 18, 29 |
| 11-173 222-15 | 9 | 12-341 150-15 | 23, 31 | 91-000 011-15 | 21 | 91-009 618-05 | 18, 29 |

| No. 零件号 | Seite Page Página 页号 | No. 零件号 | Seite Page Página 页号 | No. 零件号 | Seite Page Página 页号 | No. 零件号 | Seite Page Página 页号 |
|-------------------|-------------------------------|-------------------|-------------------------------|---------------|-------------------------------|-------------------|-------------------------------|
| 91-009 624-05 | 18 | 91-018 136-12 | 21 | 91-118 430-25 | 13 | 91-140 347-01 | 10 |
| 91-009 648-25 | 29 | 91-018 339-05 | 22 | 91-118 683-05 | 19 | 91-140 349-05 | 10, 11, 27 |
| 91-009 652-91 | 13 | 91-018 348-91 | 22 | 91-119 421-05 | 14 | 91-140 351-91 | 10 |
| 91-010 013-05 | 15, 27 | 91-018 350-05 | 22 | 91-119 590-05 | 18, 29 | 91-140 352-05 | 10 |
| 91-010 022-05 | 18 | 91-018 358-75/770 | 16 | 91-120 735-92 | 24 | 91-140 353-05 | 10 |
| 91-010 026-21 | 13, 28 | 91-018 467-70/895 | 18, 29 | 91-129 768-90 | 32 | 91-140 358-05 | 10 |
| 91-010 061-24/060 | 20 | 91-018 487-05 | 11, 27 | 91-129 917-91 | 36 | 91-140 359-05 | 10 |
| 91-010 062-22 | 30 | 91-018 799-91 | 28 | 91-140 085-05 | 11, 27 | 91-140 360-05 | 10 |
| 91-010 115-05 | 13, 28 | 91-018 889-24/060 | 30 | 91-140 086-12 | 11, 27 | 91-140 363-12 | 10 |
| 91-010 116-05 | 13, 28 | 91-019 676-05 | 18 | 91-140 101-05 | 16 | 91-140 366-05 | 10 |
| 91-010 126-92 | 21 | 91-021 486-41 | 32 | 91-140 102-05 | 16 | 91-140 367-05 | 10 |
| 91-010 146-92 | 30 | 91-027 289-15 | 35 | 91-140 104-05 | 24 | 91-140 368-05 | 10 |
| 91-010 180-05 | 28 | 91-027 370-05 | 35 | 91-140 120-05 | 17 | 91-140 372-05 | 10 |
| 91-010 181-25 | 13, 28 | 91-027 371-12 | 35 | 91-140 121-91 | 17 | 91-140 378-05 | 14 |
| 91-010 184-05 | 13, 28 | 91-027 651-75/699 | 34 | 91-140 122-92 | 24 | 91-140 379-92 | 14 |
| 91-010 185-05 | 13, 28 | 91-029 692-75/792 | 35 | 91-140 123-91 | 17 | 91-140 394-05 | 10 |
| 91-010 186-15 | 13, 28 | 91-032 087-45 | 9 | 91-140 148-05 | 24 | 91-140 403-91 | 29 |
| 91-010 196-05 | 16 | 91-033 915-21 | 34 | 91-140 155-11 | 30 | 91-140 405-91 | 18, 29 |
| 91-010 221-05 | 20, 21 | 91-038 801-75/699 | 34 | 91-140 199-02 | 23, 31 | 91-140 413-05 | 22 |
| 91-010 596-05 | 16, 18, 29 | 91-056 578-91 | 19 | 91-140 201-05 | 30 | 91-140 414-05 | 22 |
| 91-010 704-15 | 21 | 91-057 720-15 | 11 | 91-140 202-05 | 30 | 91-140 415-05 | 22 |
| 91-010 825-05 | 14 | 91-063 048-05 | 12 | 91-140 241-15 | 23, 31 | 91-140 450-25 | 10 |
| 91-010 937-05 | 13 | 91-069 037-15 | 24 | 91-140 242-05 | 23, 31 | 91-140 481-01 | 15 |
| 91-011 778-05 | 14 | 91-069 335-72/893 | 35 | 91-140 253-05 | 23, 31 | 91-140 516-75/770 | 16, 24, 30 |
| 91-012 492-25 | 18, 29 | 91-100 213-05 | 12 | 91-140 256-05 | 22 | 91-140 539-91 | 22 |
| 91-013 040-92 | 16 | 91-100 366-15 | 10 | 91-140 257-05 | 22 | 91-140 560-90 | 24 |
| 91-013 091-05 | 13 | 91-100 396-15 | 22 | 91-140 258-05 | 22 | 91-140 561-91 | 24 |
| 91-013 153-05 | 24 | 91-100 404-15 | 30 | 91-140 260-91 | 20 | 91-140 563-05 | 24 |
| 91-013 188-05 | 24 | 91-105 447-25 | 13, 28 | 91-140 273-05 | 11, 27 | 91-140 564-92 | 24 |
| 91-013 191-05 | 13 | 91-107 669-75/895 | 9 | 91-140 292-91 | 14 | 91-140 576-91 | 12 |
| 91-013 193-91 | 13 | 91-107 886-15 | 21 | 91-140 300-01 | 25 | 91-140 582-15 | 32 |
| 91-015 519-05 | 28 | 91-108 015-02 | 16 | 91-140 336-15 | 15 | 91-140 710-91 | 26 |
| 91-015 664-05 | 21 | 91-118 196-12 | 10 | 91-140 342-01 | 11, 27 | 91-140 711-15 | 26 |

| No. 零件号 | Seite Page Página 页号 | No. 零件号 | Seite Page Página 页号 | No. 零件号 | Seite Page Página 页号 | No. 零件号 | Seite Page Página 页号 |
|-------------------|-------------------------------|-------------------|-------------------------------|-------------------|-------------------------------|-------------------|-------------------------------|
| 91-140 712-11 | 26 | 91-141 542-05 | 23, 31 | 91-141 679-71/698 | 18, 29 | 91-176 332-25 | 13, 28 |
| 91-140 715-05 | 26 | 91-141 545-05 | 23, 31 | 91-141 687-70/698 | 9 | 91-202 336-00 | 18, 29 |
| 91-140 720-15 | 26 | 91-141 546-05 | 23, 31 | 91-141 694-05 | 14 | 91-229 070-70/895 | 33 |
| 91-141 085-05 | 24 | 91-141 550-71/951 | 23 | 91-141 706-05 | 24 | 91-264 357-05 | 19 |
| 91-141 087-05 | 30 | 91-141 551-71/951 | 31 | 91-141 707-11 | 25 | 91-264 358-05 | 19 |
| 91-141 099-05 | 11, 27 | 91-141 563-01 | 23, 31 | 91-141 710-72/893 | 29 | 91-266 114-15 | 9 |
| 91-141 100-91 | 11 | 91-141 566-71/951 | 23 | 91-141 711-91 | 16 | 91-700 082-15 | 13, 28 |
| 91-141 101-15 | 11 | 91-141 567-71/951 | 31 | 91-141 829-92 | 15 | 91-700 364-25 | 9 |
| 91-141 102-05 | 11 | 91-141 572-12 | 20 | 91-141 831-15 | 15 | 91-700 412-25 | 13 |
| 91-141 192-92 | 20, 30 | 91-141 573-75/951 | 20 | 91-141 837-05 | 26 | 91-700 510-15 | 14, 16 |
| 91-141 193-92 | 15, 27 | 91-141 608-91 | 11 | 91-141 848-91 | 14 | 91-700 592-15 | 15 |
| 91-141 195-91 | 15, 27 | 91-141 609-01 | 11 | 91-141 850-91 | 10 | 91-700 689-15 | 16, 20, 24 |
| 91-141 307-05 | 11 | 91-141 610-05 | 11 | 91-141 851-91 | 10 | 91-700 785-15 | 23, 24, 30, 31 |
| 91-141 312-71/951 | 11 | 91-141 612-91 | 17 | 91-141 852-91 | 10 | 91-700 961-15 | 18, 29 |
| 91-141 313-75/951 | 11 | 91-141 617-75/698 | 9 | 91-141 853-91 | 14 | 91-700 996-15 | 19 |
| 91-141 314-71/951 | 27 | 91-141 618-75/895 | 9 | 91-141 953-91 | 22 | 91-709 610-71/698 | 29 |
| 91-141 315-75/951 | 27 | 91-141 620-72/893 | 17 | 91-164 056-05 | 26 | 95-665 735-91 | 36 |
| 91-141 426-15 | 9 | 91-141 621-75/895 | 9 | 91-166 452-21 | 19 | 95-774 464-05 | 19 |
| 91-141 427-15 | 9 | 91-141 624-75/895 | 9 | 91-166 559-25 | 13 | 95-774 466-91 | 19 |
| 91-141 428-15 | 9 | 91-141 625-72/895 | 32 | 91-168 025-05 | 12 | 96-711 962-05 | 14 |
| 91-141 441-15 | 26 | 91-141 626-05 | 15 | 91-168 319-12 | 23, 24, 30, 31 | 99-135 161-85 | 25 |
| 91-141 442-15 | 13 | 91-141 628-75/895 | 9 | 91-168 331-05 | 26 | 99-137 001-05 | 9 |
| 91-141 443-15 | 13 | 91-141 660-11 | 26 | 91-168 375-70/893 | 35 | 99-137 151-45 | 19 |
| 91-141 452-12 | 27 | 91-141 662-15 | 15 | 91-168 376-15 | 35 | | |
| 91-141 454-91 | 27 | 91-141 663-15 | 15 | 91-168 480-15 | 17 | | |
| 91-141 502-15 | 13 | 91-141 664-72/895 | 9 | 91-169 523-05 | 14 | | |
| 91-141 520-75/951 | 31 | 91-141 665-91 | 9 | 91-171 049-05 | 19 | | |
| 91-141 521-75/951 | 23 | 91-141 666-05 | 11 | 91-171 808-05 | 10 | | |
| 91-141 525-01 | 23, 31 | 91-141 667-05 | 11 | 91-173 664-15 | 27 | | |
| 91-141 535-05 | 23, 31 | 91-141 668-15 | 13 | 91-174 879-05 | 19 | | |
| 91-141 536-90 | 23, 31 | 91-141 674-05 | 29 | 91-175 023-05 | 24 | | |
| 91-141 540-15 | 23, 31 | 91-141 675-05 | 18, 29 | 91-175 126-05 | 24 | | |
| 91-141 541-05 | 23, 31 | 91-141 676-15 | 9 | 91-176 267-05 | 10 | | |

1245

1246

UNTERKLASSEN-AUSSTATTUNG

SUBCLASS PARTS

COMPOSICIÓN DE LAS SUBCLASES

子机型-设备

-6/01

Für allgemeine Näharbeiten. For ordinary sewing operations.
(Standardform des Teilesatzes.) (Standard part set.)

Para trabajos de costura en general.
(Juego de piezas estándar.)

适用于一般性缝纫工作。
(套件的标准型式。)

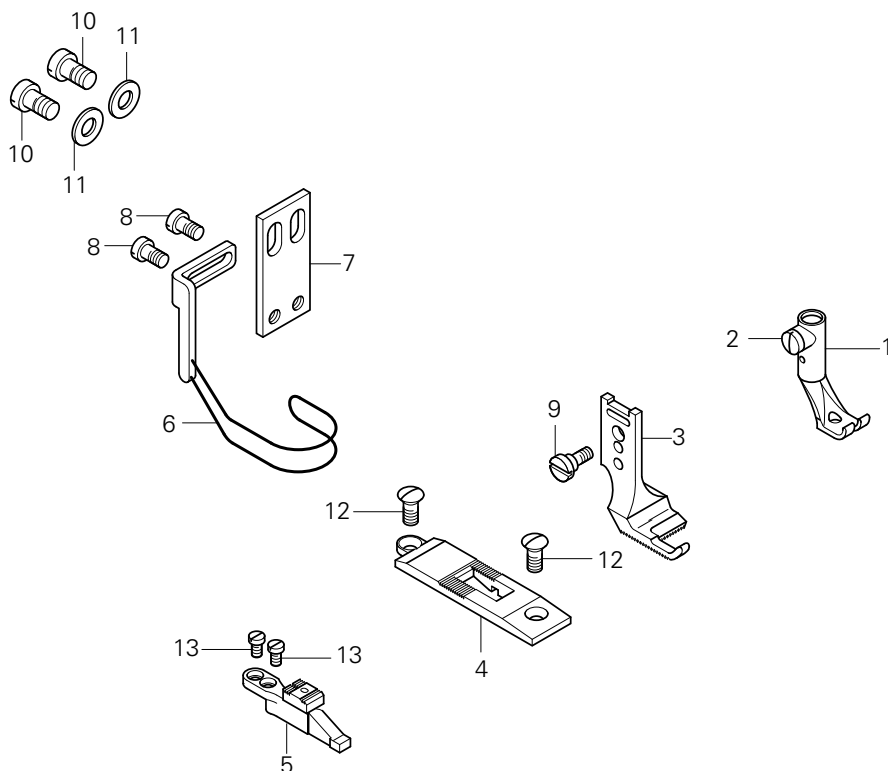

| Pos.-Nr. Item No. 序号 | Ausführung Model Typo 款式 | Stichlänge Stitch length Largo de puntada 针距 | Teile-Nr. Part No. 零件号 |
|----------------------------|-----------------------------------|---|------------------------------|
| 1 - 8 | CN8 [◆] | 8,0 | 91-201 574-93/001 |
| 1 - 2 | | | 91-049 269-93/006 |
| 2 | | | 91-000 085-15 |
| 3 | | | 91-049 585-04/004 |
| 4 | | | 91-048 922-04/002 |
| 5 | | | 91-026 745-04/003 |
| 6 - 8 | | | 91-057 741-91 |
| 6 | | | 91-057 742-91 |

| Pos.-Nr. Item No. 序号 | Ausführung Model Typo 款式 | Stichlänge Stitch length Largo de puntada 针距 | Teile-Nr. Part No. 零件号 |
|----------------------------|-----------------------------------|---|------------------------------|
| 7 | | | 91-057 720-15 |
| 8 | | | 11-108 171-15 |
| 9 | | | 91-100 366-15 |
| 10 | | | 11-108 222-15 |
| 11 | | | 12-305 144-15 |
| 12 | | | 91-000 422-25 |
| 13 | | | 91-000 407-15 |

-17/01

Arbeitsgang
 Operation
 Operación
 工序

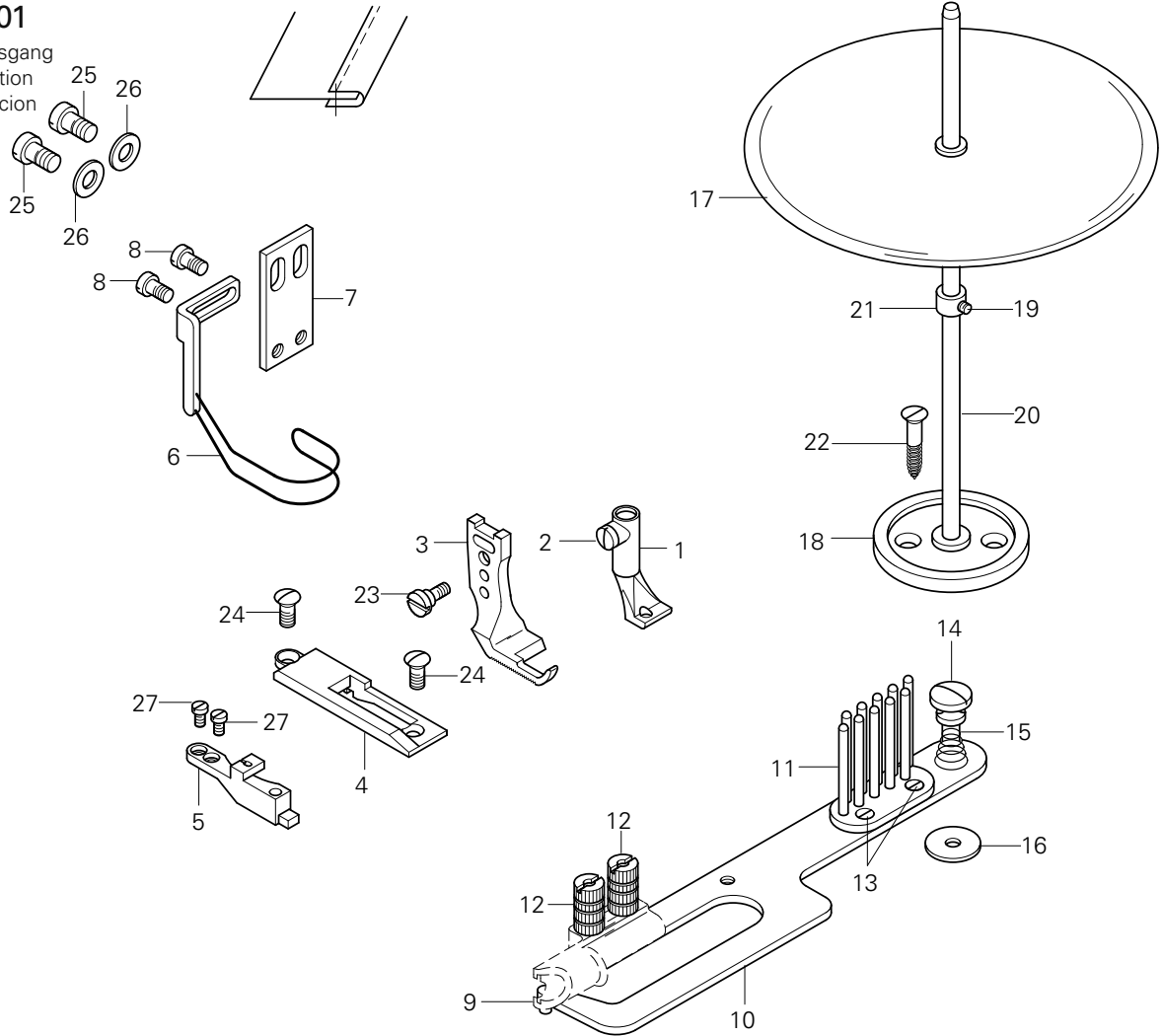

| Pos.-Nr. Item No. 序号 | Ausführung Model Typo 款式 | Stichlänge Stitch length Largo de puntada 针距 | Teile-Nr. Part No. 零件号 | Pos.-Nr. Item No. 序号 | Ausführung Model Typo 款式 | Stichlänge Stitch length Largo de puntada 针距 | Teile-Nr. Part No. 零件号 |
|----------------------------|-----------------------------------|---|------------------------------|----------------------------|-----------------------------------|---|------------------------------|
| 1 - 16 | CN8 [◆] | 8,0 | 91-201 581-93/003 | 14 | | | 91-000 824-25 |
| 1 - 2 | | | 91-042 819-93/024 | 15 | | | 91-040 624-25 |
| 2 | | | 91-000 085-15 | 16 | | | 91-028 036-25 |
| 3 | | | 91-149 227-04/001 | 17 - 22 | | | 91-043 943-70/895 |
| 4 | | | 91-150 862-04/002 | 17 | | | 91-043 124-71/895 |
| 5 | | | 91-045 591-04/003 | 18 | | | 91-043 945-75/895 |
| 6 - 8 | | | 91-057 721-91 | 19 | | | 91-043 947-92 |
| 6 | | | 91-057 697-91 | 20 | | | 91-043 946-25 |
| 7 | | | 91-057 720-15 | 21 | | | 91-000 388-15 |
| 8 | | | 11-108 171-15 | 22 | | | 11-472 250-55 |
| 9 | | | 5 | 23 | | | 91-100 366-15 |
| 10 - 16 | | | 91-045 607-90 | 24 | | | 91-000 422-25 |
| 10 | | | 91-053 752-21 | 25 | | | 11-108 222-15 |
| 11 | | | 91-044 251-21 | 26 | | | 12-305 144-15 |
| 12 | | | 91-001 592-25 | 27 | | | 91-000 422-25 |
| 13 | | | 91-000 380-15 | | | | |

5 / [◆] siehe Kapitel 2 Erläuterung der Schlüsselzeichen
 see chapter 2 Explanation of key markings
 véase el Cap. 2 Explicaciones de los signos clave
 见第2章标记说明

[▲] Weitere Unterklassen und Ausführungen auf Anfrage
 Further Subclasses and versions on enquiry
 Otras subclases y tipos, sobre demanda
 更多的子机型和款式请咨询

-6/01

Für allgemeine Näharbeiten. For ordinary sewing operations.
(Standardform des Teilesatzes.) (Standard part set.)

Para trabajos de costura en general.
(Juego de piezas estándar.)

适用于一般性缝纫工作。
(套件的标准型式。)

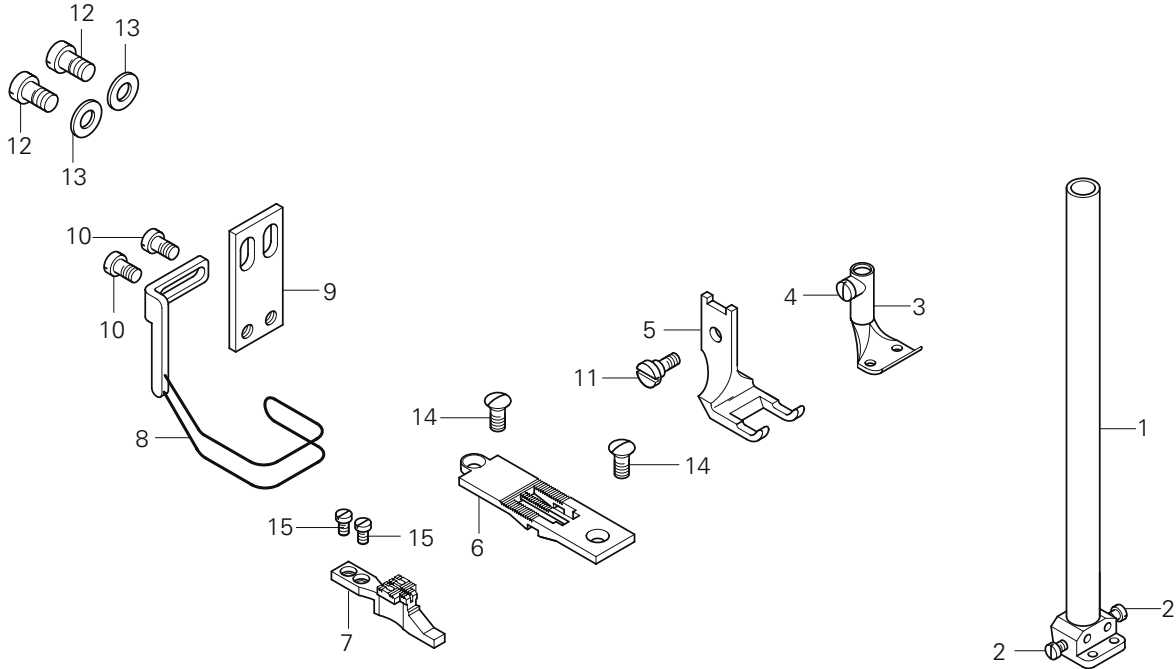

| Pos.-Nr. Item No. 序号 | Ausführung Model 款式 | Stichlänge Stitch length Largo de puntada 针距 | Nadelabstand Needle gauge Distancia entre agujas 机针间距 | Teile-Nr. Part No. 零件号 |
|----------------------------|---------------------------|---|--|------------------------------|
| 1 - 10 | CN [◆] | 6,0 | 6,4 | 91-201 111-93/001 |
| | CN [◆] | 6,0 | 10,0 | 91-201 111-93/002 |
| | CN8 [◆] | 8,0 | 12,0 | 91-201 114-93/004 |
| 1 - 2 | CN [◆] | 6,0 | 6,4 | 91-710 749-93/010 |
| | CN [◆] | 6,0 | 10,0 | 91-710 749-93/015 |
| | CN8 [◆] | 8,0 | 12,0 | 91-710 749-93/017 |
| 2 | | | | 91-173 664-15 |
| 3 - 4 | CN [◆] | 6,0 | 6,4 | 91-049 267-93/006 |
| | CN [◆] | 6,0 | 10,0 | 91-049 267-93/010 |
| | CN8 [◆] | 8,0 | 12,0 | 91-049 267-93/011 |
| 4 | | | | 91-000 085-15 |
| 5 | CN [◆] | 6,0 | 6,4 | 91-040 429-04/007 |
| | CN [◆] | 6,0 | 10,0 | 91-040 429-04/010 |
| | CN8 [◆] | 8,0 | 12,0 | 91-049 668-04/010 |
| 6 | CN [◆] | 6,0 | 6,4 | 91-040 434-04/051 |
| | CN [◆] | 6,0 | 10,0 | 91-040 434-04/054 |
| | CN8 [◆] | 8,0 | 12,0 | 91-158 601-04/016 |

| Pos.-Nr. Item No. 序号 | Ausführung Model 款式 | Stichlänge Stitch length Largo de puntada 针距 | Nadelabstand Needle gauge Distancia entre agujas 机针间距 | Teile-Nr. Part No. 零件号 |
|----------------------------|---------------------------|---|--|------------------------------|
| 7 | CN [◆] | 6,0 | 6,4 | 91-040 433-04/086 |
| | CN [◆] | 6,0 | 10,0 | 91-040 433-04/093 |
| | CN8 [◆] | 8,0 | 12,0 | 91-040 433-04/098 |
| 8 - 10 | CN [◆] | 6,0 | | 91-057 722-91 |
| | CN8 [◆] | 8,0 | | 91-057 806-91 |
| 8 | CN [◆] | 6,0 | | 91-057 708-91 |
| | CN8 [◆] | 8,0 | | 91-057 807-91 |
| 9 | | | | 91-057 720-15 |
| 10 | | | | 11-108 171-15 |
| 11 | | | | 91-100 366-15 |
| 12 | | | | 11-108 222-15 |
| 13 | | | | 12-305 144-15 |
| 14 | | | | 91-000 422-25 |
| 15 | | | | 91-000 407-15 |



Europäische Union
Wachstum durch Innovation – EFRE

PFAFF Industriesysteme und Maschinen AG

Hans-Geiger-Str. 12 - IG Nord
D-67661 Kaiserslautern

Telefon: +49 - 6301 3205 - 0
Telefax: +49 - 6301 3205 - 1386
E-mail: info@pfaff-industrial.com

Hotlines:

Technischer Service / Technical service:
Service technique / Servicio técnico: +49 - 175 2243-101

Nähetechnik-Fachberatung / Application consultancy:
Conseiller de couture et technique / Asesor técnico: +49 - 175 2243-102

Ersatzteile-Hotline / Spare-parts hotline:
Hotline - Pièces détachées / Hotline Repuestos: +49 - 175 2243-103

Gedruckt in der BRD / Printed in Germany / Imprimé en la R.F.A. / Impreso en la R.F.A